

# TRAVELSMITH®

## VENDOR PARTNERSHIP MANUAL

NEW CORPORATE OFFICE

773 SAN MARIN DRIVE, SUITE 2300

NOVATO, CA 94945

415-798-3000

[WWW.TRAVELSMITH.COM](http://WWW.TRAVELSMITH.COM)

UPDATED MARCH, 2011

THIS MANUAL SUPERSEDES ALL PREVIOUSLY ISSUED VERSIONS  
AND IS EFFECTIVE IMMEDIATELY.

**I. INTRODUCTION**

VENDOR PARTNERSHIP MANUAL AGREEMENT ..... 4

**II. SAMPLES**

FIT & PRODUCT DEVELOPMENT..... 5  
CATALOG PHOTOGRAPHY..... 5  
TOP-OF-PRODUCTION (TOP)..... 5

**III. MANUFACTURING**

TRIM CARD ..... 6  
PRODUCT SPECIFICATIONS STANDARDS..... 7  
QUALITY ASSURANCE ..... 7  
CLASSIFICATION OF DEFECTS ..... 7  
INSPECTION FAILURE CRITERIA .....10  
MEASUREMENT GUIDELINES .....12  
FABRIC AND GARMENT TESTING .....23  
CONSUMER PRODUCT SAFETY IMPROVEMENT ACT.....24  
CALIFORNIA'S PROPOSITION 65 í .25  
PRODUCT LABELS.....26  
LABEL PLACEMENT .....27

**IV. PACKAGING AND PACKAGE LABELS**

ITEM PACKAGING & LABELING.....28  
CASE ATTRIBUTE REQUIREMENTS .....32  
CASE PACKING .....33  
CASE SEALING/PALLETIZING .....33

**V. FULFILLMENT**

DOMESTIC VENDOR ROUTING GUIDE .....35  
BOL .....36  
IMPORT REQUIREMENTS.....37  
INT'L VENDOR ROUTING UIDE.....38  
ADVANCE SHIPMENT NOTICE (ASN) .....39  
EDI/ VENDOR NET STANDARDS .....39  
PACKING SLIPS.....41  
EXTERNAL CASE LABELING.....43

**VI. PRODUCT SAFETY .....47**

**VII. COMPLIANCE**

TERMS AND CONDITIONS OF PURCHASE.....50  
CHARGEBACK POLICY .....56  
RETURN TO VENDOR POLICY .....58  
VENDOR PARTNERSHIP SOCIAL RESPONSIBILITY GUIDELINES .....58

**VIII. APPENDIX**

DEFINITIONS.....61

## **I. INTRODUCTION**

TravelSmith is focused on expanding our business in a healthy and profitable manner. We are committed to providing our customers with outstanding customer service, our investors with superior returns, and our employees with a productive, rewarding environment. We are further committed to the responsibilities of corporate ethics in both the local and wider communities in which we do business.

Our vendors are important stakeholders in the success of our business and we wish to build a mutually profitable partnership. This vendor manual will provide you with an overview of our Company policies and procedures. We want to provide a very clear set of expectations for our vendor partnership, and this manual is designed as a guidebook for those expectations.

TravelSmith is committed to satisfying our customers. Our products are *GUARANTEED 100%. NO QUESTIONS. NO EXCEPTIONS.* *We promise a full refund if a customer is not **totally satisfied at any time** with a TravelSmith product.*

## **VENDOR PARTNERSHIP MANUAL AGREEMENT**

### **CONFIRMATION OF RECEIPT**

This form states that you understand all the standards and requirements outlined in the Vendor Partnership Manual. By signing and returning this form, you confirm that you have received and understand the TravelSmith Vendor Partnership Guidelines and agree to comply with all the standards and business practices as listed. Please sign, date and return this form to the TravelSmith Vendor Compliance Department. If you are unclear with any portion of the manual, please contact us at (415) 798-3027. By agreeing to do business with TravelSmith, vendors are held to the standards in this manual and are subject to non-compliance charges incurred by TravelSmith.

If TravelSmith discovers the undersigned vendor has violated any of the Vendor Partnership Guidelines, TravelSmith may choose to cancel any outstanding orders, terminate the business relationship, and/or possibly pursue legal action.

\*\*The most recent updates to this vendor manual, as well as many helpful forms and instructions, can always be accessed online at <http://ccsginc.com>. If you don't already have one, you will be able to request a username and password from the home page\*\*

# TRAVELSMITH<sup>®</sup>

## FAX COVER SHEET

TO: JEN MCAFEE  
FAX: (513) 645-4178  
# PAGES: 1

FROM VENDOR: \_\_\_\_\_  
VENDOR CONTACT NAME: \_\_\_\_\_  
CONTACT EMAIL: \_\_\_\_\_  
CONTACT PHONE: \_\_\_\_\_  
CONTACT FAX: \_\_\_\_\_  
CONTACT ADDRESS: \_\_\_\_\_

RE: TravelSmith Vendor Partnership Manual

TravelSmith is focused on expanding our business in a healthy and profitable manner. We are committed to providing our customers with outstanding customer service. We are further committed to the responsibilities of corporate efforts in both the local and wider communities in which we do business. Our vendors are important stakeholders in the success of our business and we wish to build a mutually profitable partnership. We require that our vendors assure that our standards will be met as outlined in the Vendor Partnership Manual. We want to provide a very clear set of expectations for our vendors, if you have questions regarding any portion of the Vendor Partnership Manual, please contact the Vendor Compliance Manager at (415) 798-3027.

As an authorized representative, the undersigned agrees to the terms and conditions of the Vendor Partnership Manual.

Name: \_\_\_\_\_  
Signature: \_\_\_\_\_  
Title: \_\_\_\_\_  
Company: \_\_\_\_\_  
Date: \_\_\_\_\_

## II. SAMPLES

At TravelSmith we require a variety of samples throughout our development process. Each sample has a specific purpose and is outlined below. Please work with your TravelSmith contact to obtain necessary information and timing of each sample. All sampling costs are the vendor's responsibility.

### **FIT & PRODUCT DEVELOPMENT**

Fit & Product Development samples are requested from the inception of the design through final approval. These samples are used to perfect the details and fit of a product. A completed TravelSmith sample card must be attached to the left (wearer's side) underarm seam or waistband.

### **CATALOG PHOTOGRAPHY**

Photography samples are required for all products introduced into the line. Photography samples should meet all design, color, fabric, trim, finding, fit and labeling specifications. If a product is to be marked with "SAMPLE", it should be done in an inconspicuous location. One photo sample in each colorway offered, in our sample size, is required. Samples must be received on or before the deadline assigned by your TravelSmith contact. A 12" x 12" fabric swatch (of each colorway), and trim card (template on following page) must be included w/ the samples. Please see page 6 of the manual for a copy of the trim card. Photo sample costs are the vendor's responsibility.

### **TOP-OF-PRODUCTION (TOP)**

#### **APPAREL**

Two (2) TOP samples are required for all apparel. TOP samples are to be received within two (2) weeks of cutting the first bulk production. TOP samples are to be representative of the bulk cutting, sewing and packaging.

Accuracy is very important. The samples will be used when accepting goods into stock (any discrepancies could result in delays at the warehouse). A product produced in a sample room or facility other than where production is made is not acceptable.

If the samples do not meet specification and quality standards, the Technical Designer or Merchandising Representative will advise corrections to be made to bulk production. Merchandise received at the distribution center that does not meet specification and quality standards are subject to 100% inspection or return to vendor at the expense of the vendor.

Two samples, plus 6x6 color swatches for additional colors, are to be submitted to the Merchandising Department, with the exception of Women's Plus Size samples. In this case, only one (1) sample, plus color swatches are required. Upon approval, one Missy/Men's sample will be forwarded to the distribution center for use in quality inspections and the other will be kept by Merchandising for reference. The Women's Plus Size sample will be forwarded to the distribution center. The samples must conform to all fit, quality, packaging and labeling standards. TOP sample costs are the vendor's responsibility.

If TOPs are not received prior to PO delivery at the DC, a chargeback will be assessed to the vendor.

### **OTHER CATEGORIES**

For off-line apparel buys, follow the rules above; we need 2 TOPs and 1 photography sample. Also, a soft copy spec sent to the technical designer or merchant is required concurrent or prior to the receipt of the TOP sample.

For hard goods, accessory and footwear items, please work with your merchant on what samples or information is needed.

# TRAVELSMITH TRIM CARD

SEASON:  
STYLE #  
DESCRIPTION:

VENDOR:  
DESCRIPTION:  
COLORS:

DATE:

SHELL FABRIC:

LINING/POCKETING/ INTERLINING:

SUPPLIER:	SUPPLIER:
CODE #	CODE #
COLORWAYS:	COLORWAYS:
FABRIC CONTENT/CONSTRUCTION/WEIGHT:	FABRIC CONTENT/CONSTRUCTION/WEIGHT:

MAIN/CARE CONTENT/ COUNTRY OF ORIGIN/PO LABELS:

BUTTONS AND MISC. TRIMS:

	SUPPLIER:
	CODE #
	SIZE:

POLYBAG GUMSTICKER:

THREAD

--	--

ZIPPER & PULL

SUPPLIER:	*FOR ADDITIONAL TRIMS PLEASE USE SEPARATE PAGE
CODE #	
SIZE:	

### III. MANUFACTURING

#### PRODUCT SPECIFICATIONS STANDARDS

TravelSmith's goal is to provide the highest quality product and service for our customers. The vendor is responsible for maintaining complete and accurate records of the in-line, end-of-line quality inspections and final packaged product audits. Audits should be performed using a 4.0% AQL.

The factory must inspect fabric prior to cutting to ensure that only first quality material is utilized in production. If there is any question about acceptability, send production yardage to your Merchandising Representative for review. Accurate and complete inspection records must be maintained and available to a TravelSmith Representative upon request.

#### QUALITY ASSURANCE

All merchandise is inspected using a 4% AQL military sampling plan upon receipt at the TravelSmith distribution center for conformance to quality, measurement, and packaging and labeling specifications. The sampling plan may be increased or decreased depending upon the vendor's history of overall product quality. If the product passes these criteria, the entire shipment is accepted. If the product fails the inspection, the entire shipment is put on hold.

The disposition of a shipment placed on hold is made based on discussions with the Merchandising and Inventory Planning team members. The vendor is notified of the problem and whether the shipment will be returned to the vendor or is to be 100% inspected. In either case, charges will be assessed to the vendor for operating costs incurred in resolving the problems. For more information on chargeback and return to vendor policies, see Section VII - Compliance.

#### CLASSIFICATION OF DEFECTS

Defects occur in varying degrees. Minor defects are acceptable; Major or Critical defects are rejected. Defect acceptability is based on the effect the damaged product will have on the customer. Price, end use, materials and construction of a product dictate different levels of acceptance by the TravelSmith customer. Defects are classified as follows:

1. **Minor Defect**  
the product serviceability or wearability is not affected. If noticed by the customer, would not cause any objection. The defect will not affect the comfort or fit of the product.
2. **Major Defect**  
A product would be rendered unusable. The defect would adversely affect the serviceability of the product or shorten the life of the product. The defect would be obvious to the customer and would result in a return.
3. **Critical Defect**  
The product would definitely be unusable, or would require early repair or replacement. The defect will cause a product to be uncomfortable, not fit or may cause an injury to the consumer. A product with a critical defect would most assuredly result in a return.

#### PRODUCT ZONES

The position of a construction defect or flaw may determine the acceptance or rejection of a product. The area on a product and the visibility to the customer defines zones. Each product has specific zones that are more important than others and guidelines are defined accordingly.

##### **ZONE 1**

Areas of a product with extremely high visibility and are likely to be viewed from a close distance at the time of purchase or receipt. Minor flaws in this area may be classified as Major and would be cause for rejection of the product.

##### **ZONE 2**

Areas of the product that are not visibly dominant, but are seen in normal use. Minor flaws in this area would be evaluated based upon size, color and intended use of the product to determine acceptability.

**ZONE 3**

An area of the product not seen in normal everyday use. Minor or cosmetic flaws are more acceptable here than in any other area of the product. Flaws will be evaluated by product and intended end use.

**Dress Zone Chart**

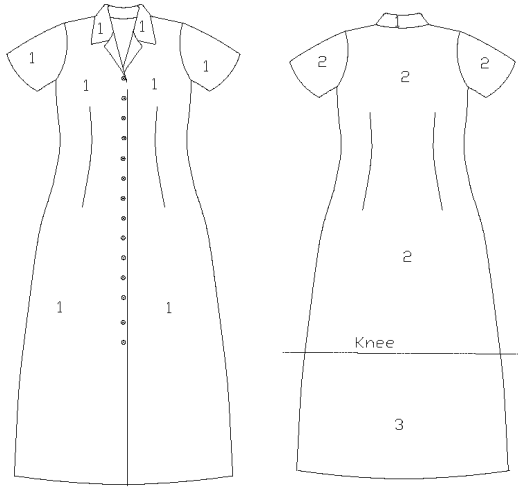

**Sweater Zone Chart**

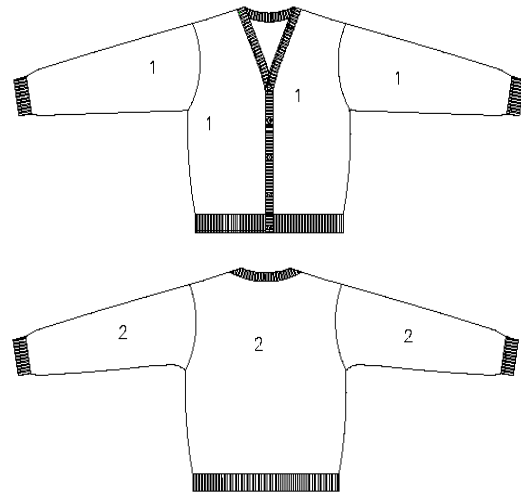

**Shirt Zone Chart**  
**Skirt Zone Chart**

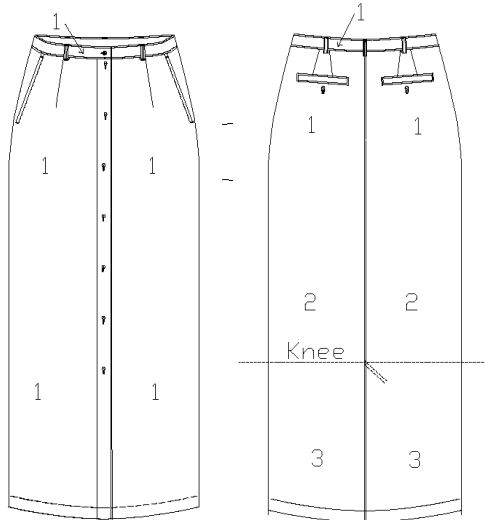
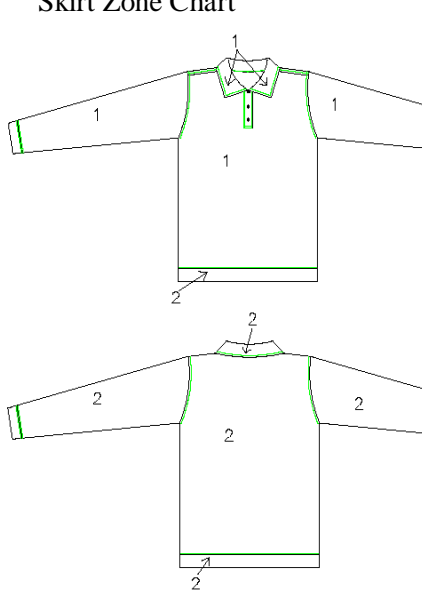

**Outerwear Zone Chart**

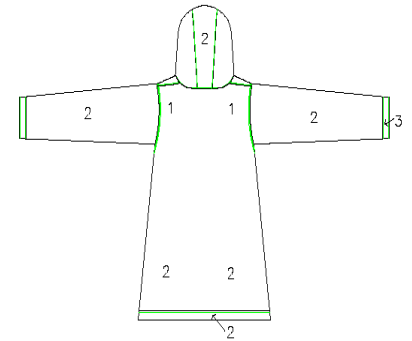

Pants Zone Chart

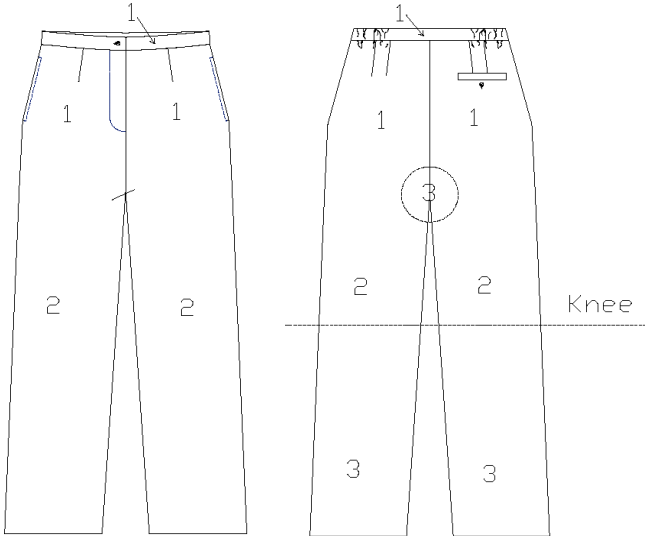

## **INSPECTION FAILURE CRITERIA**

### **FABRIC DEFECTS**

- Any hole or blemish
- Snagged or pulled threads or yarns
- Foreign matter in the fabric
- Heavy barre or machine lines
- Uneven dyeing or printing
- Slubs, runs and misweaves, as defined by TravelSmith
- Poor hand, i.e., stiff
- Seam Slippage

### **CONSTRUCTION DEFECTS**

#### **STITCHING AND SEAMS**

- Broken, uneven or skipped stitches
- Excessively tight or loose tension
- Needle cuts
- Crooked, puckered, curled wavy or uneven seams
- Open seams
- Uneven topstitching
- Use of monofilament thread, unless approved
- Seam allowance too narrow in areas of stress, e.g., sleeve or front placket, causing garment to tear.

#### **BUTTONS, BUTTONHOLES & FINDINGS**

- Component not aligned
- Buttons not securely sewn
- Defective or malfunctioning part
- Component color not as specified
- Poorly made buttonholes; not cut open, too small or too large
- Loose threads

#### **POCKETS**

- Uneven in size, shape or location
- Flap incorrect shape
- Sewn in puckers or pleats

#### **LABELS**

- Incorrect labels
- Labels not positioned as specified
- Incorrect information
- Handwritten, illegible, incomplete or missing

#### **PRESSING**

- Burn, scorch or other mark on surface of garment
- Excessively wrinkled garments, unless specified

#### **HEMS**

- Puckered or twisted

- Uneven hem width

#### **THREADS & YARNS**

- Excessive and / or loose threads
- Thread other than specified color, size or type

#### **DIMENSIONS**

- Corresponding parts should be symmetrical and measure the same unless otherwise specified
- Measurement specifications outside of specified tolerance

#### **REPAIRS**

- Poorly mended, noticeable repair
- Loose threads from repair

#### **CONSTRUCTION**

- Foreign objects sewn into garment
- Parts sewn on incorrectly
- Raw edges or untrimmed edges, unless specified
- Incorrect or missing bar tack

#### **BELT LOOPS/WAISTBANDS**

- Raw edges on belt loop
- Missing, crooked, incorrectly placed or wrong number of belt loops
- Uneven waistband width (+/- 1/8", but not both)
- Waistbands that have excessive puckering, twisting, turn-back or fullness

#### **COLLAR/NECK**

- Collar points improperly shaped or not uniform (+/- 1/8")
- Collar band or under collar showing above top collar
- Neck opening off-center
- Neck puckered or stretched

#### **MATCHING**

- Uneven stripe alignment (front must be straight)
- Plaids, checks, stripes not matching at center front or other specified location
- Pockets/plackets not matched to body as specified

#### **PLACKETS**

- Crooked more than 1/4" from top to bottom
- Length not as specified (+/- 1/4")
- Sewn off-grain
- Distorted or uneven width

#### **GENERAL DEFECTS**

- Soilage-oil marks, spots, ink, rings left after cleaning soil
- Any measurement not as specified or out of tolerance
- Any item not conforming to construction specifications
- Substitute or missing parts, unless pre-approved by TravelSmith

- Shaded parts
- Marked seconds
- Color off standard-must be within acceptable shade bands when available

## MEASUREMENT GUIDELINES

All apparel must be measured in the following manner unless otherwise stated on the specification package. All measurements are to be taken with the garments laid on a flat surface. The garment should be in a natural position, free of tension and with wrinkles smoothed out. Measure wearer's left side (i.e. sleeve, armhole, thigh, and inseam).

All measurements should be taken with a standard plastic or metal tape measure. Periodically, the tape measure must be checked against a metal ruler for accuracy.

Please note:

- All buttons and zippers must be completely closed
- Button spacing is measured center of button to center of button
- Extended measurements should be the minimum stretched measurement. Fully extend the fabric until it lays flat. The fabric should not be distorted, nor should the elastic be extended to its full dimension.
- Belt loops are measured at center of loop
- Measure from center of seam for felled seams and edge of seam for safety stitch or single needle joined seams.

### 1. ACROSS FRONT (HIGH CHEST)

- With buttons and zippers closed, measure straight across from armhole seam to armhole seam. Specify the distance down from the high point shoulder for the standard size on the spec.

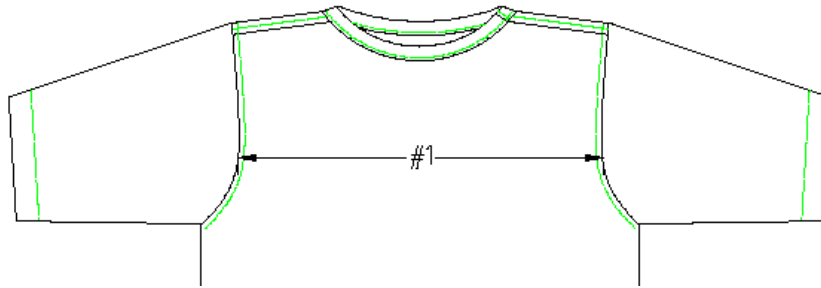

### 2. ACROSS SHOULDER

- Lay garment flat with back facing you and measure straight across from LPS (low point shoulder) to LPS.
- Measure straight across back from point to point.

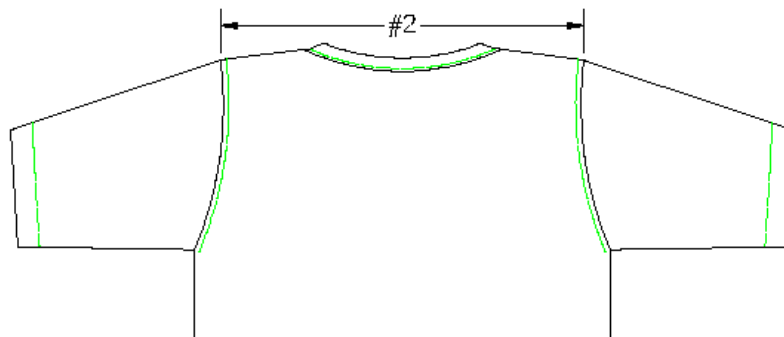

### 3. ACROSS BACK

- With buttons and zippers closed, measure straight across from armhole seam to armhole seam. Specify the distance down from the high point shoulder for the standard size on the spec.

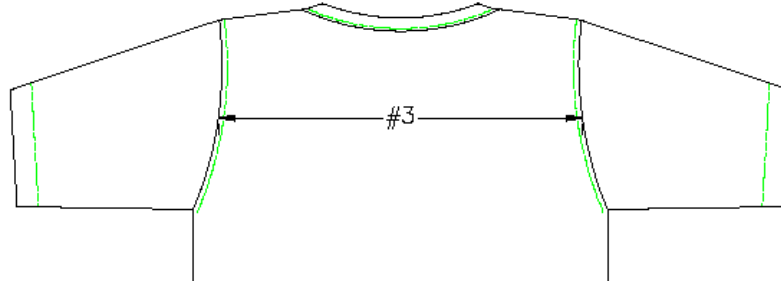

4. **CHEST/BUST\***

- With the front of the garment facing you, measure straight across body 16 down from armhole seam.

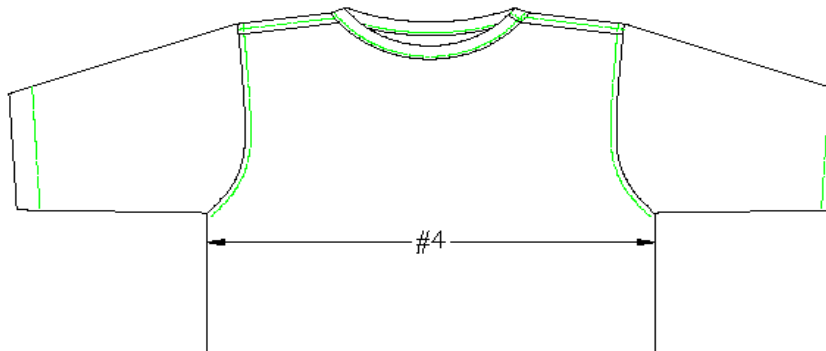

5. **WAIST\***

**A. RELAXED**

- Measure along the center of the waistband. Top edge of front and back waistbands must be even. All closures must be fastened and button must be at the end of the buttonhole.

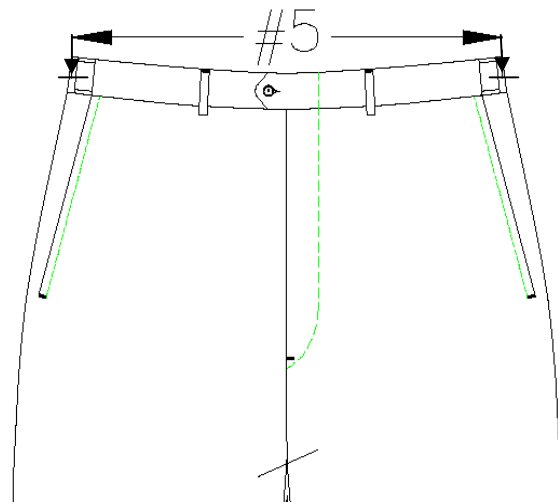

## **B. EXTENDED**

- Stretch elastic waist to release all gathers in garment. Do not overextend. Insert measuring tape into top of waistband (no more than 1/2ö) and measure across the top of the opening.

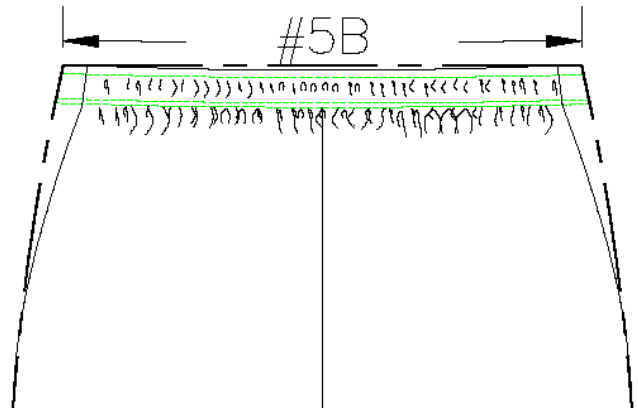

## **6. HIGH HIP (3 POINT MEASUREMENT)\***

- Lay garment flat with front facing you.
- Measure down from BWB (bottom of waistband) at center front and side seams. Measuring from side to side you should form a slight öVö shape on the garment.
- Specify the distance down from BWB (bottom of waistband) to each point for the standard size on the spec.

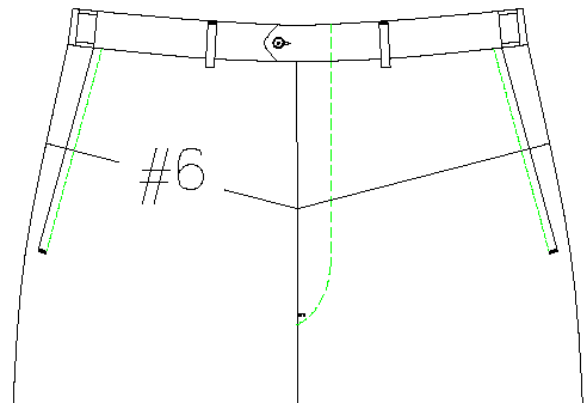

## **7. LOW HIP/SEAT (3 POINT MEASUREMENT)\***

- Lay garment flat with front facing you.
- Measure down from BWB (bottom of waistband) at center front and side seams. Measuring from side to side you should form a slight öVö shape on the garment.
- Specify the distance down from BWB (bottom of waistband) to each point for the standard size on the spec.

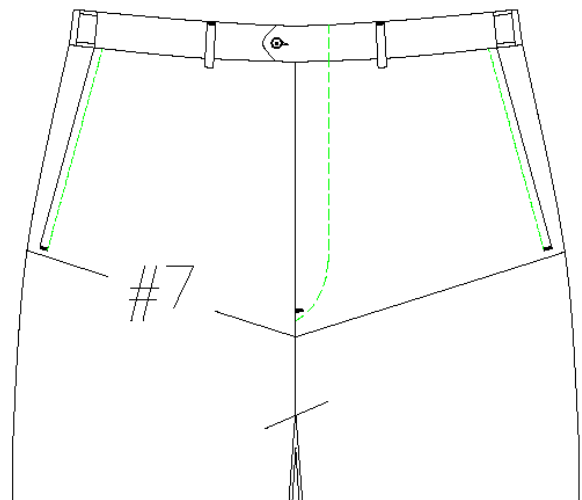

## **8. SWEEP\***

- Measure along the bottom edge of garment, from side seam to side seam. If garment has side slits or shirrtail, measure straight across the top of the slits or shirrtail.

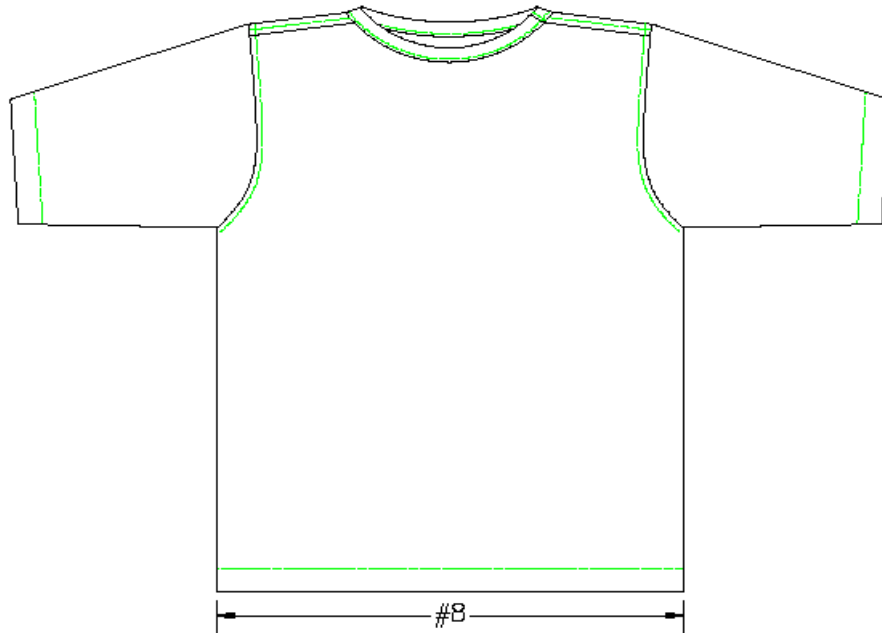

**9. THIGH\***

Lay one leg flat. Measure across garment 10 below crotch point, keeping the tape measure parallel to hem.

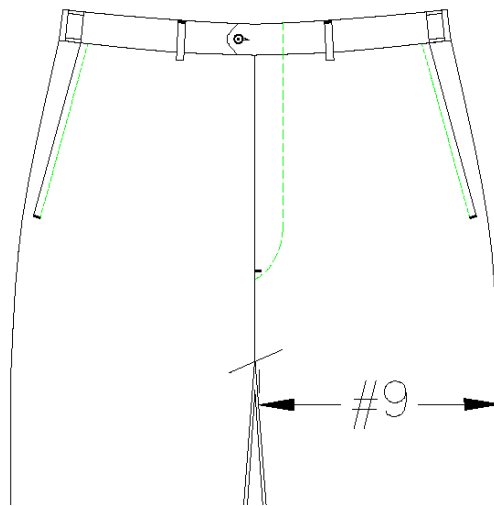

### **10. KNEE\***

- Lay one leg flat.
- Measure down pant inseam 12½" for women's, 12" for women's petite, and 15" for men's.
- Measure straight across the leg from fold to fold keeping tape measure parallel to hem.

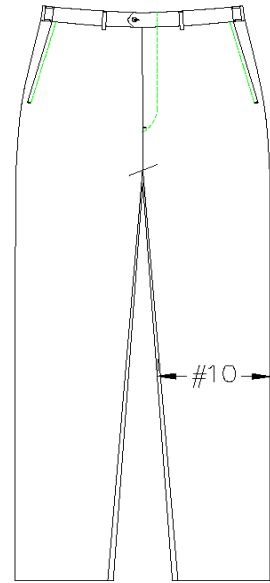

### **11. LEG OPENING\***

- Lay one leg flat.
- Measure straight across bottom opening from fold to fold.

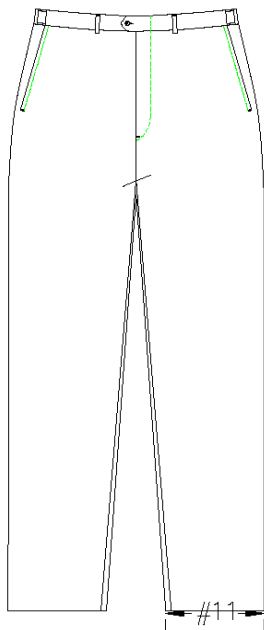

### **12. INSEAM**

- Lay one leg flat.
- Measure from crotch point down leg (along seam) to bottom of the leg opening.

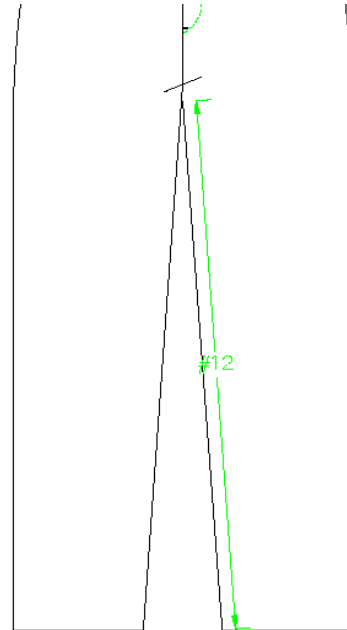

**13. FRONT RISE**

- Lay garment flat with front facing you.
- Measure from BWB to crotch seam, following the shape of the front rise.

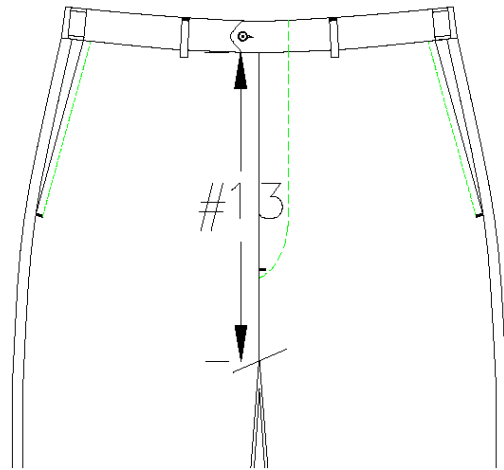

**14. BACK RISE**

- Lay garment flat with back facing you.
- Measure from BWB to crotch seam, following the shape of the rise seam.

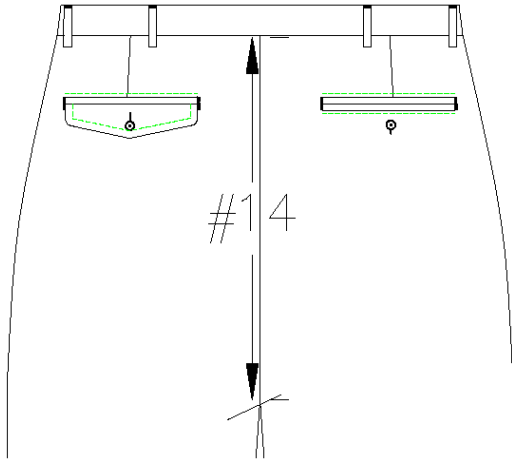

**15. ARMHOLE STRAIGHT**

- Measure straight from LPS to underarm seam.

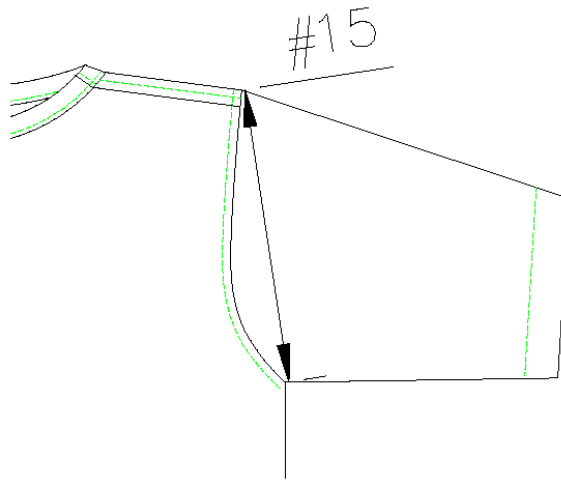

**16. NECK CIRCUMFERENCE**

- Undo all buttons and lay garment flat so that the inside of the garment is facing you.
- Measure from center of button to farthest end of buttonhole along inside of collar.

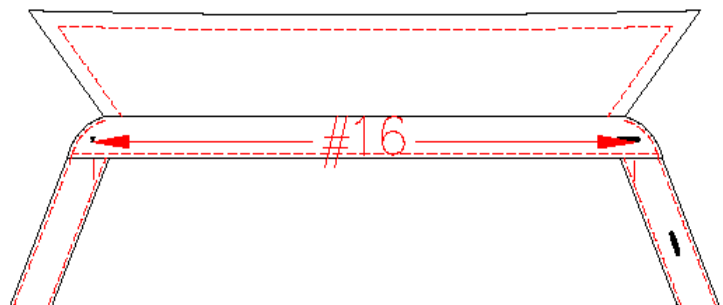

**17. NECK WIDTH**

- Lay garment flat.
- Measure straight, from high point shoulder to high point shoulder at the base of the collar or neck trim.

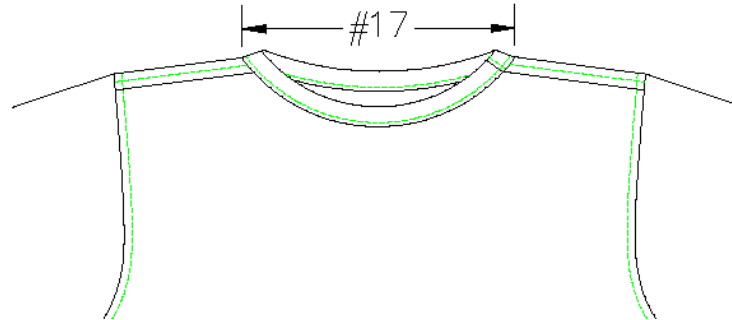

**18. FRONT NECK DEPTH**

- Lay garment flat with front facing you.
- Place a ruler straight across at high point shoulder points.
- From center point, measure straight down to neck seam (base of collar, stand or neck trim) at the center front.
- On V-neck garments with button closure, measure to the center of the top button.

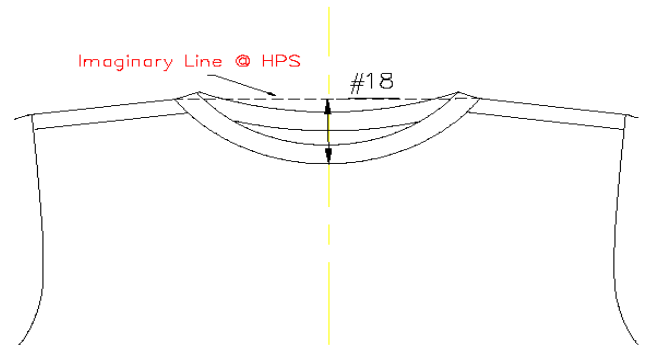

**19. BACK NECK DEPTH**

- Lay garment with back facing you.
- Place a ruler straight across at high point shoulder points.
- From center point, measure straight down to neck seam (base of collar, stand or neck trim) at the center back.

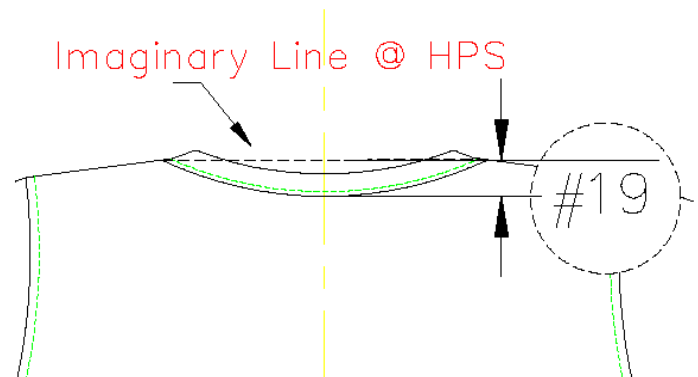

**20. COLLAR LENGTH POINT TO POINT**

- Undo all buttons and lay collar flat so that the inside of the garment is facing you.
- Measure along the outer collar edge from collar point to collar point.

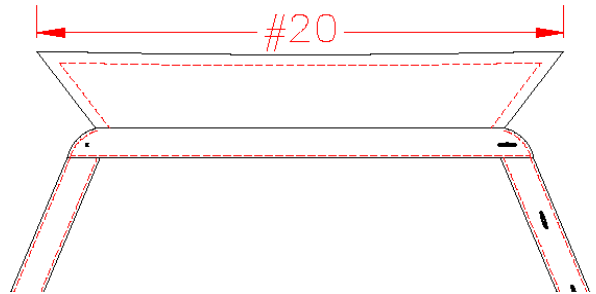

**21. MINIMUM NECK STRETCH**

- Lay garment flat with rib or collar edges even.
- Stretch neck without breaking stitches and measure across the neck opening where the rib or collar meets the neck seam.

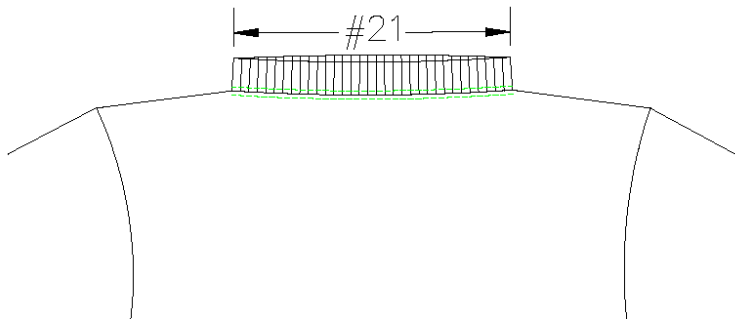

**22. CENTER BACK TO WAIST PLACEMENT**

- Measure from center of back neck seam to waistline of garment.

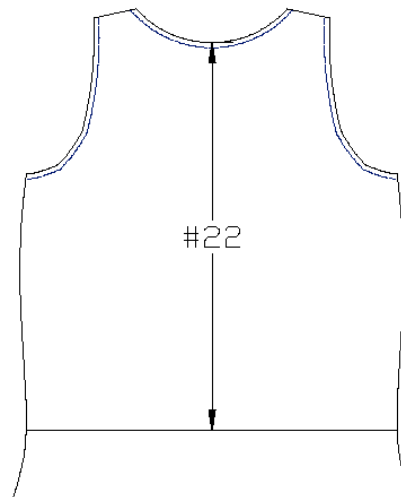

**23. BODY LENGTH FROM HIGH POINT SHOULDER**

- Measure from high point shoulder down the body to the bottom of the garment.

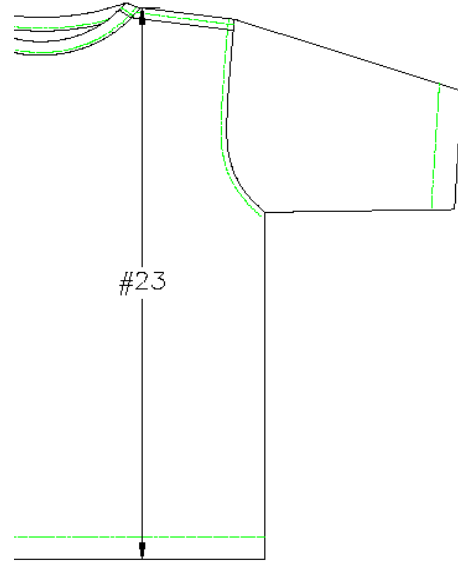

**24. CENTER BACK LENGTH**

- Measure from waistband (if no waistband, measure from top) or back neck seam to the bottom of the hem.

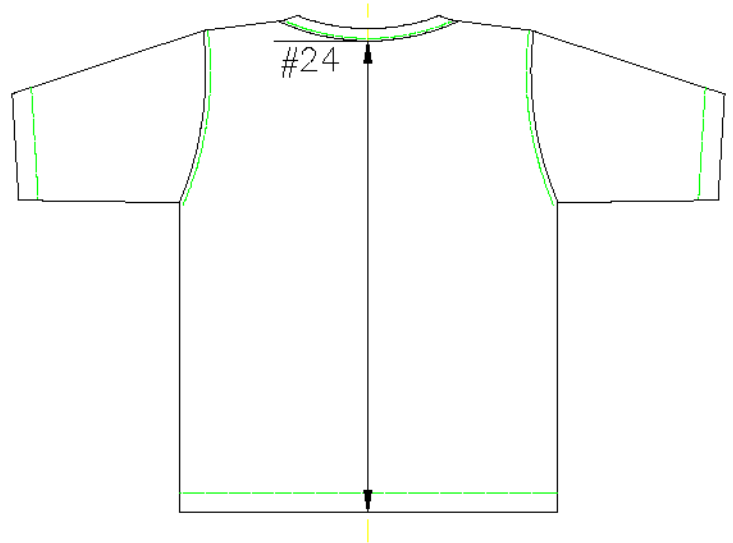

**25. SLEEVE LENGTH**

**A. GARMENTS WITH SET-IN SLEEVES (3 POINT MEASUREMENT)**

- With back of garment facing you, measure from center back to shoulder seam; pivot and measure to cuff or end of sleeve following fold.

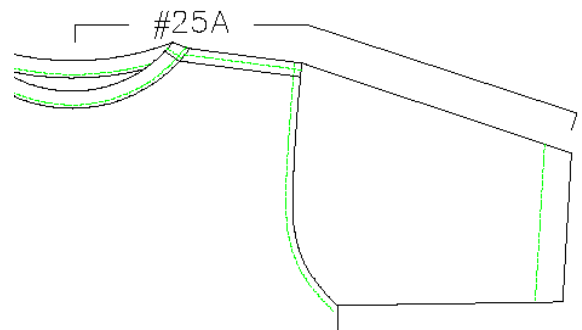

**B. GARMENTS WITHOUT SET-IN SLEEVES (2 POINT MEASUREMENT- RAGLANS, SADDLE SHOULDER)**

- With back of garment facing you, measure straight from center back neck to cuff or end of sleeve.

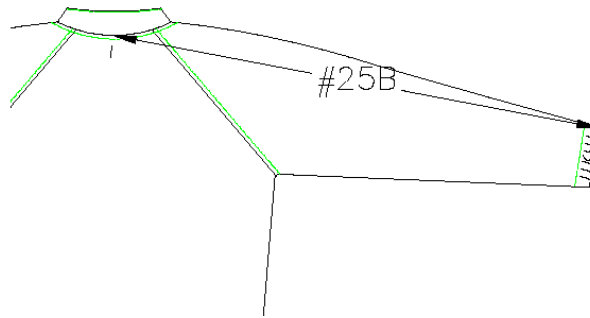

**26. MUSCLE\***

- Measure 1ö down from armhole at underarm seam.
- Measure straight across sleeve parallel to the sleeve opening.

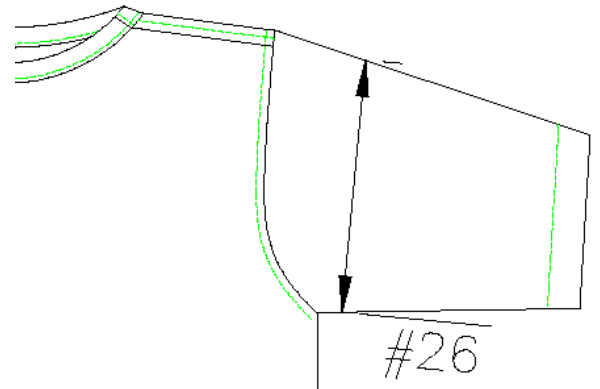

**27. SLEEVE OPENING\***

- Measure straight across finished edge of sleeve.

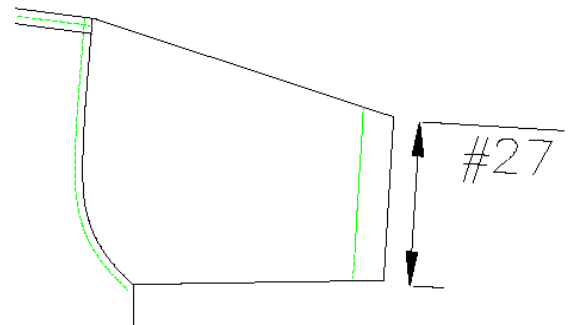

*\*Measurement is doubled.*

**FABRIC AND GARMENT TESTING**

TravelSmith requires all TravelSmith branded garments to be lab tested. It is the factory/vendor's responsibility to test production fabric and garments to ensure all products meet all the ASTM and AATCC standards. TravelSmith has a testing program with Bureau Veritas. All testing standards are given in our Bureau Veritas Test Manual found at <http://ccsginc.com>. If you wish to use another testing lab, please get approval from the Vendor Compliance and Quality Control Manager. All test results should be reviewed and approved prior to cutting bulk fabric. Please notify TravelSmith immediately if there are any concerns about fabric quality or performance.

## CPSIA

The Consumer Product Safety Improvement Act (CPSIA), which was enacted on August 14, 2008, imposes new requirements on a wide variety of products that are regulated by the U.S. Consumer Product Safety Commission (CPSC).

### REGULATION SUMMARY:

- Section 14(a)(1) of the Consumer Product Safety Act, as recently amended by the CPSIA, requires a *General Certification of Conformity* (GCC) to be issued with respect to every product that is subject to any consumer product safety rule, ban, standard, or regulation enforced by the CPSC. This form can be downloaded from our vendor site <http://ccsginc.com/travel.htm>.
- The GCC is required for all import and domestic products subject to all applicable rules, bans, standards and regulations. Products without the required certificate cannot be imported or distributed in commerce in the United States.
- The GCC requirement is immediately applicable to products manufactured on or after November 12, 2008.
- TravelSmith expects ALL import & domestic vendors to meet the GCC requirement per the CPSC. The law applies to ALL applicable products and for ALL brands (National, Vendor, Market, No brands, etc.).
- Refer to website for CPSIA GCC requirements information ([www.cpsc.gov/about/cpsia/cpsia.html](http://www.cpsc.gov/about/cpsia/cpsia.html)).
- Refer to website for CPSC Regulated Products list ([www.cpsc.gov/businfo/reg.html](http://www.cpsc.gov/businfo/reg.html)).

### PROCEDURE:

#### 1. VENDORS PRODUCING TRAVELSMITH BRANDED PRODUCT:

TravelSmith has always held the expectation that TravelSmith vendors have an established, effective and compliant quality assurance and testing program that insures your manufactured products meet all U.S. safety & regulatory requirements as well as TravelSmith's standards.

According to the regulations issued by the CPSIA, the GCC must be issued by the importer for imported products and by the manufacturer for domestic products. Vendors must ensure that the GCC is prepared accurately and consistently.

- ***If TravelSmith is the Importer of Record:*** the rough draft GCC is created by the vendor and agent ONLY after successful completion of all required TravelSmith testing; then the GCC is to be sent to the Vendor Compliance department at TravelSmith via fax (414) 921-5140 or email [vendorweb@travelsmith.com](mailto:vendorweb@travelsmith.com) for review, approval & issuance.
- ***If TravelSmith is NOT the Importer of Record \*\*OR\*\* the product is produced domestically:*** the GCC is created by the domestic distributor/vendor ONLY after successful completion of all required TravelSmith testing.

### TRAVELSMITH TESTING REQUIREMENTS:

- Vendors to contact the TravelSmith 3<sup>rd</sup> Party Laboratory for panel testing. This should be noted on the test and to TravelSmith Sourcing by listing the TravelSmith item# and TravelSmith name for each applicable product.
- In regards to 16 CFR 1303 Lead in substrates and coatings, vendors must certify compliance to the 300ppm lead in substrates and 90 ppm lead in coatings beginning now.
- Vendors to keep on record certificate/statement of proper lead content from their finish suppliers for each batch of finish ordered. The vendors must maintain these records with GCC records for 5 years and must be available to TravelSmith within 24hrs of request.

### IMMEDIATE VENDOR ACTIONS REQUIRED:

- ***Vendors to begin sending a GCC for all applicable product shipments that were manufactured on or after November 12, 2008.***
- Vendor to provide the GCC along with other required import shipping documents.
  - ***If TravelSmith is the Importer of Record:*** the vendor is responsible to provide the TravelSmith issued GCC in their shipping documents to TravelSmith's forwarder.
  - ***If TravelSmith is NOT the Importer of Record:*** the vendor is responsible to provide the GCC in their shipping documents for import.
- The vendor must maintain records of the GCC issued for 5 years. GCC must be available upon request to TravelSmith within 24 hours of request.

## **2. VENDOR PRODUCING NON-TRAVELSMITH BRANDED PRODUCT**

(national brands, vendor brands, market brands, no brands, etc.)

TravelSmith has always held the expectation that NON-TravelSmith branded product vendors have an established, effective and compliant quality assurance and testing program that insures your products meet all U.S. safety & regulatory requirements as well as TravelSmith's standards.

### **IMMEDIATE VENDOR ACTIONS REQUIRED:**

- Vendors to execute a GCC based on a reasonable testing program.
- Vendor to provide the GCC along with other required import shipping documents.
  - ***If TravelSmith is the Importer of Record;*** the vendor is held responsible to provide the GCC in their shipping documents to TravelSmith's forwarder.
  - ***If TravelSmith is NOT the Importer of Record;*** the vendor is held responsible to provide the GCC in their shipping documents for import.
- The vendor must maintain records of the GCCs issued for 5 years. GCC must be available upon request to TravelSmith within 24 hours of request.
- 

### **California's Proposition 65 – California Health & Safety Code Section 25214.1-25214.4.2**

Proposition 65 (Prop 65) is a California law that was approved by California voters in a referendum in 1986. It requires the state to keep a list of chemicals that cause cancer or reproductive toxicity. If a product contains a chemical on the list, Prop 65 testing report must be provided. You can access the list of 800-plus chemicals on the California Office of Environmental Health Hazard Assessment website at [http://www.oehha.ca.gov/prop65/prop65\\_list/Newlist.html](http://www.oehha.ca.gov/prop65/prop65_list/Newlist.html). Lead, phthalates and other common chemicals are on the Proposition 65 list.

Vendors must provide a test report including Prop 65 test data from a TravelSmith-approved independent testing laboratory.

**PRODUCT LABELS**

The TravelSmith logo is registered and required on all TravelSmith brand products. TravelSmith labeling requirements are in conformance with the Federal Trade Commission regulations. Labeling is an important part of the product identification. If products are found to be improperly labeled during our quality inspection process the shipment will be rejected.

**MAIN LABELS AND SIZE TABS FOR WOMEN’S AND MEN’S**

Men’s and women’s will use labels ordered from AZI only. The label styles are mitre fold and end fold. All garments will have a size tab with the country of origin under the alpha or numeric size. Joint garments (Men’s and Women’s similar styles) will use the MENS or Womens designation on top of the size tab. The size tab will be sewn to the bottom of the main label, centered.

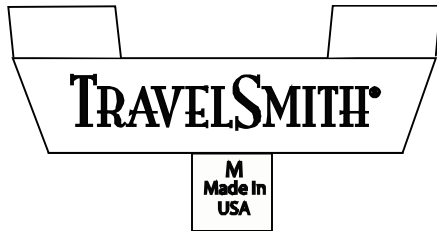

**CONTACT INFORMATION**

American Zabin International (AZI)

US Label contact:

Joe Hoenester

[joe@aziusa.com](mailto:joe@aziusa.com)

(949) 851-0883 ph

(949) 851-1421 fax

Hong Kong Label contact:

Pian Chim

[pian\\_chim@zabin.com.hk](mailto:pian_chim@zabin.com.hk)

(852)3758 7000 ext. 166

**CARE AND CONTENT LABELS**

The care content label is printed and sourced by each vendor or factory. Each label will be printed on a white satin ribbon quality with black printing. Size should be 1 1/2 (2.5cm) wide by the length that is determined by care instructions.

In addition to the information on the label shown, this label can be used to give additional country of origin information, for example MENS Made in USA of Imported Fabric.

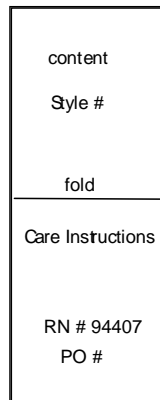

## LABEL PLACEMENT

**Read through the below placement suggestions. Please note: there will always be an exception to these rules. Please check with your merchant to confirm unusual placement of any label.**

### Main and Size Tab Labels

1. Mitre Fold ó WL096471 - Use for Knit tops and dresses, woven tops with collars but without collar stands, knit and woven elastic waistband pants or skirts. Set at Center Back horizontal seam.
2. End Fold ó WL096470 ó Use for knit and woven jackets, woven shirts and dresses with collar stands, woven tunic tops, bottoms with waistbands, sweaters, outer wear pouches with outside logo, all sleepwear tops and bottoms.
3. Size Tab- WL096472 ó Sew centered at the bottom of the main label.

### Care Label Placement

1. Left side seam 3-4ö up from finished hem or edge óShirts, Jackets, Sweaters, Tunics. For Dresses, 5-6ö up from finished edge in left side seam.
2. In waistband seam, to the wearerø left of center back ó pants, skirts, culottes, gauchos, capris, or shorts with waistbands or elastic waist.

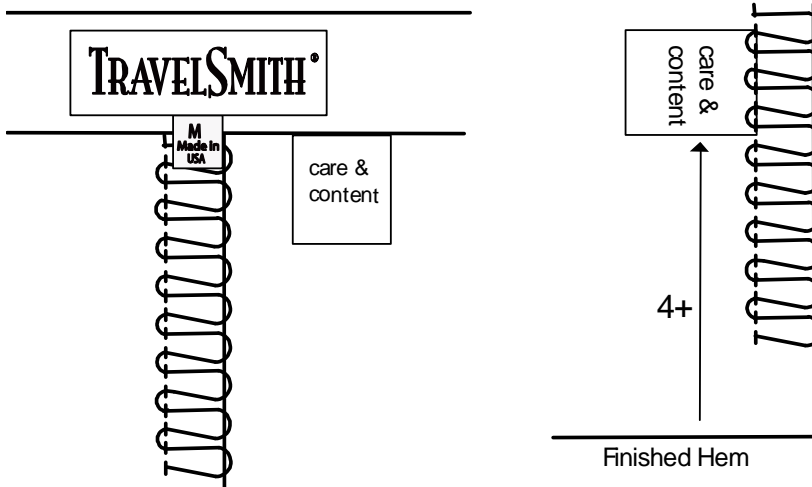

## IV. PACKAGING AND PACKAGE LABELS

### ITEM PACKAGING AND LABELING

#### APPAREL

The packaging for TravelSmith branded products is intended to protect the goods from soil or damage. Appropriate stabilizers are required to improve the product appearance during all phases of shipping, i.e. cardboard to retain shape of a shirt or collar bands to stabilize neck shape on banded collared shirts. Utilize the correct size polybag for products to eliminate excess movement or wrinkles.

Polybags may be obtained from:

Domestic Contact:  
CAL SUPPLY  
2855 Volpey Way  
Union City, CA 94587  
Phone: (800) 562-2625  
Fax: (510) 429-0426

International Contact:  
KAM WAI POLYETHYLENE BAG CO.  
Flat I, 6/F, Block 1  
Kingswin Ind Bldg., 32-50 Lei Muk Road,  
Kwai Chung, N.T. / Hong Kong  
Phone: (852) 2423-3545/2420-6709  
Fax: (852) 8169-0802  
Email: ada@kwnc.com.hk

Sizes available are:

<u>Size</u>	<u>Description</u>
12"	Bottom hanger box
17"	Garment polybag
21x4x4	Garment polybag 1000/cs 30# roll
14x19 - 3" flip	Garment polybag
12x15 - 3" flip	Garment polybag 1500/cs
16x23.75 - 2.5 flip	Garment polybag 500/cs

Another supplier may be used. All polybags (unless otherwise specified) must be a minimum film gauge of 1.25 mil. Any polybag under 1.25mil requires a suffocation safety-warning label.

- Polybags can be made of high clarity virgin or recycled resins. Low-density polyethylene, polypropylene and ethylene vinyl acetate is acceptable.
- All polybags must be sealed. The closure can be heat-sealed (bag must have air vent holes), folded and taped, or have self-sealing, reclosable adhesive strips.

#### ITEM LABELING CONTENTS

All merchandise must be individually labeled (affixed to the item or its packaging) with the following information:

- a. TravelSmith Item/Style # (from PO) and Vendor Item # (if applicable)
- b. TravelSmith Specific Color Name (if applicable)

- c. Style (if applicable)
- d. Size (if applicable). For Apparel, denote øRegularø, øPetiteø, øShortø, øLongø.

**Every item shipped to the TravelSmith Distribution Center must have the TravelSmith sku labeled on it. A sku includes the style number, the 3 digit alpha color code and the size code. An example would be 5566 BLK L. The vendor’s sku is not required. If you are not certain what your TravelSmith sku is, check your purchase order, or ask your control buyer.**

**ITEM LABELING CHARACTERISTICS**

All label fonts must be in Univers or Arial 12 or ¾ point.  
The product type labels must meet the specified requirements:

- a. Locate polybag labels on the front lower right
- b. Locate suit/garment labels on top right
- c. Locate box labels on outside upper right
- d. Locate shoe box labels on lower right
- e. Recommended size is 1” x 2-5/8”. Smaller sized labels must be approved by Vendor Relations Coordinator.

**POLYBAG ITEM LABEL**

List the style #, color code, and size as they appear on your PO; examples shown below.  
The following is an example of a Womenø Crimson size medium top:

**32101 CRI M**

The following is an example of a Womenø black size 10 petite pant.

**22156 BLK 10P**

The following is an example of a Womenø plus size blue 2X shirt.

**20207 BLU 2X**

The following is an example of a Menø Indigo Jean, size 36ø waist by 32ø inseam.

8507 IND 36W 32L

The following is an example of a Menø 42 long Khaki Blazer.

8855 KHA 42L

The following is an example of a Menø Unfinished Pant.

7513 KHA 42W UNH

## **LUGGAGE AND TRAVEL ACCESSORIES**

### **PACKAGING**

All luggage or travel products must be packed in one of the following ways to prevent damage in our DC:

1. Ship-Alone Packaging: ship alone cartons are for items that are too large in size to pack with other items. These products ship to the customer in the vendor packaging due to the limited availability of stock cartons in our distribution center. All ship alone items must be packaged individually so they can survive the rigors of small parcel (UPS, and USPS) shipping.

Reshipper cartons must be brown box cartons with a minimum case burst strength of 200lbs and minimum edge crush test of 32.5 pounds (see below). All reshipper cartons must be able to pass our 14 point drop test as outlined in our drop test procedures. Failure to pass this drop test will result in additional charges due to non-compliance and the costs associated with repackaging required to enable a passing result.

\* The UCC-128 label on the outside of the carton provides sufficient item labeling. \*

2. Individually boxed inside a master carton (each inner carton must contain only ONE unit)
3. Individually polybagged or shrink-wrapped in a master carton with other single bagged same items

### **POLYBAGGING**

If you are polybagging your merchandise, we prefer you use our logo polybags if possible although it is not strictly required. If your item is too big to fit in one of our bags, or if you are shipping a non-exclusive item, you have permission to ship in a plain polybag.

### **ITEM LABEL**

All items require a product label that includes the TravelSmith style number, and if appropriate, color/size:

12345 BLU
-----------

### **ITEM LABELING CHARACTERISTICS**

1. All label fonts must be in Univers or Arial 12 point font.
2. Labels must use a permanent adhesive.
3. Locate polybag labels on the front lower right
4. Locate box labels on outside upper right
5. Recommended size is 1" x 2-5/8". Smaller sized labels must be approved by Vendor Compliance Manager.

## CASE ATTRIBUTE REQUIREMENTS

### GENERAL CAPABILITIES

Case sizes must conform to the following dimensions to be inducted on the inbound conveyor and to be stored in our reserve and active picking locations. The Vendor Relations Coordinator must approve any exceptions to the standard case size requirements.

#### STANDARD CASE SIZES:

24"(L) x 17"(W) x 8"(H)

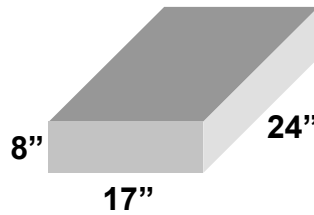

24"(L) x 17"(W) x 15"(H)

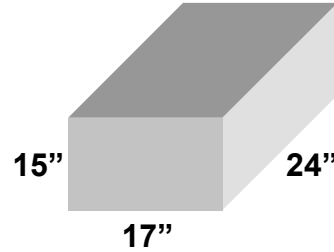

61cm(L) x 43cm(W) x 19cm(H)

61cm(L) x 43cm(W) x 38cm(H)

The above standard case sized must be utilized if the item fits within one of these cases. Any item that dictates a case size outside of the standard must fall within the following range:

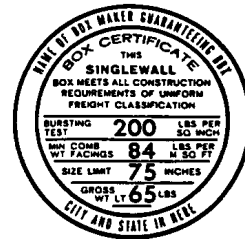
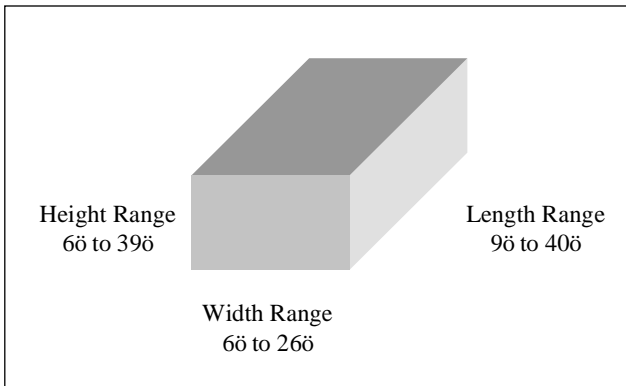

Inches can be converted to centimeters by multiplying the inch measurement by 2.54.

#### STANDARD CASE WEIGHTS:

The MINIMUM case weight is 2 lbs.

The MAXIMUM case weight is 50 lbs.

Case burst strength of 200 lbs. (91 kg) or greater.

Edge Crush Test (ECT) of 32.5 lbs. (15kg) is required.

Any type of corrugate is OK.

# 5352 BLK

10 PETITE

**BLACK**

24"(L) x 17"(W) x 8"(H)

24"(L) x 17"(W) x 15"(H)

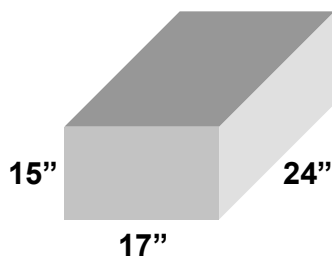
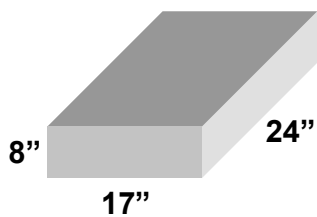

61cm(L) x 43cm(W) x 19cm(H)

61cm(L) x 43cm(W) x 38cm(H)

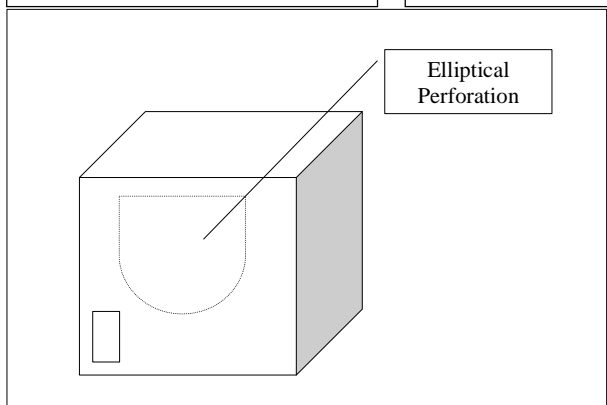

## CASE PACKING

- Cases must contain only ONE SKU (style, color, size / ie 12345 Blu S)
- Cases MUST NOT be packed with multi-unit boxes or bagging.
- Separate different soft goods SKU's with tissue paper.
- If your shipment consists of one SKU in multiple cases, the quantities per case must be the same. Only one non-uniform quantity case per SKU, per shipment, is acceptable.
- Individual cases must contain items from only one Purchase Order.
- All items must be shipped against a valid Purchase Order.

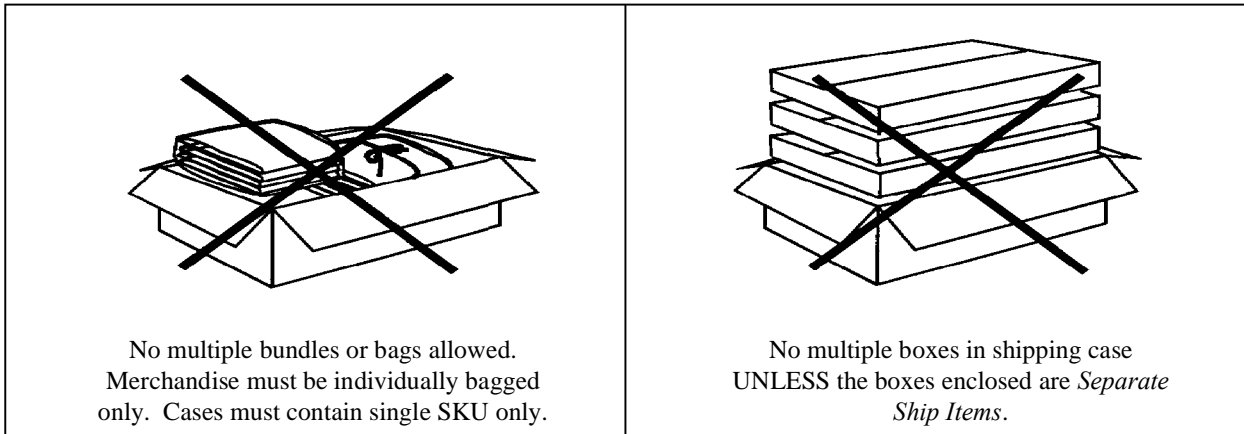

Note: A *Separate Ship Item* is an individually packaged item in a shippable box with dimensions that may exceed the above maximums.

These case packing requirements facilitate receiving and processing of the products. If you cannot conform to these requirements, please contact the TravelSmith Vendor Relations Coordinator prior to shipping.

## CASE SEALING/PALLETIZING

### TAPING AND SEALING CASES

Due to the large number of cases received at the Distribution Center, standardized case sealing simplifies inventory and quality inspections. Taping must not obscure any required case markings or labels. Below is the recommended sealing technique for the standard case:

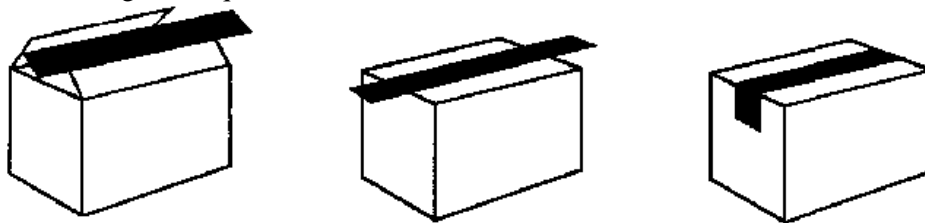

To minimize employee hazard and prevent damage to our material handling equipment, **do not secure cases with straps, bands, plastic or string** (except *Separate Ship Items*).

### PALLETIZING:

- The required pallet size is 48" long x 40" wide (1.22m long x 1m wide).
- Use 4-way pallets.
- A pallet label, including the following information, must be on all 4 sides of EACH pallet:
  - Vendor Name from PO
  - Address
  - PO #
  - PRO #

-öPLEASE DO NOT BREAK DOWN SKIDSö

- d. Cartons on the pallet must not overhang pallet length or width.
- e. Maximum height of pallet 65ö (1.65 meters) including cases and pallet.
- f. When palletizing multiple Purchase Orders, cases of the same PO should be on the same level of the pallet or on the same pallet. Shrink wrapping the cases of each PO is required.
- g. Cases of the same PO should be numbered öxx of xxö starting with ö1 of xxö.
- h. OK to combine PO's on one pallet; just jut 1 pallet label on all 4 sides
- i. Place cases on pallet so all case labels face outward as shown:

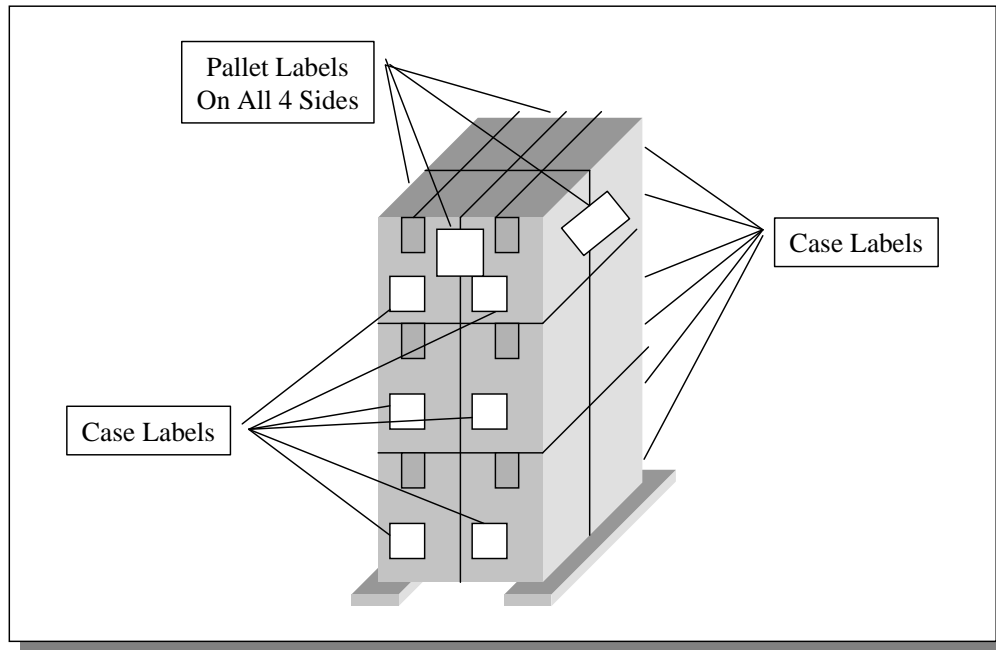

**PLEASE CONTACT THE VENDOR COMPLIANCE MANAGER AT 415-798-3027 IF YOUR FACILITY IS NOT CAPABLE OF PALLETIZING SHIPMENTS. WE WON'T REFUSE YOUR SHIPMENT IF YOU CANNOT PALLETIZE, BUT THERE WILL BE A CHARGEBACK FOR THE ADD'L HANDLING REQUIRED. TYPICALLY, THE CARRIER WILL DELIVER PARTIALS AND/OR MISPLACE ONE OR MORE CARTONS.**

**V. FULFILLMENT**

**TravelSmith**  
**NORTH AMERICA VENDOR ROUTING GUIDE**  
**Effective October 01, 2010**

Please note that Kingsgate may route shipments via LTL carriers.  
 Please be sure to record the Routing Authorization Number on the Bill of Lading.

\*Note: A username and password is required to use the Kingsgate booking portal. A username can be requested at:

<http://signup.kingsgateextranet.com>

**Standard Shipments**

<u>If Shipping</u>				
<u>From:</u>	<b>USA</b>			
<u>Shipment Weight</u>	<u>Carrier Name</u>	<u>Carrier Phone Number</u>	<u>Carrier Website/E=Mail</u>	<u>Other Information</u>
0 - 150 pounds	<b>UPS</b>	800-Pick-UPS	<a href="http://www.ups.com">www.ups.com</a>	Use UPS <u>Collect</u> Billing - Account # X03469
Over 150 pounds	<b>Kingsgate</b>	800-336-3441 x1004	<a href="http://portal.kingsgateextranet.com">http://portal.kingsgateextranet.com</a>	Kingsgate may route shipments w/ other LTL carriers.

<u>If Shipping</u>				
<u>From:</u>	<b>Canada</b>			
<u>Shipment Weight</u>	<u>Carrier Name</u>	<u>Carrier Phone Number</u>	<u>Carrier Website/E=Mail</u>	<u>Other Information</u>
0 - 150 pounds	<b>UPS</b>	800-Pick-UPS	<a href="http://www.ups.com">www.ups.com</a>	Use UPS <u>Collect</u> Billing - Account # X03469
Over 150 pounds	<b>Kingsgate</b>	800-336-3441 x1004	<a href="http://portal.kingsgateextranet.com">http://portal.kingsgateextranet.com</a>	Kingsgate may route shipments w/ other LTL carriers.

If Shipping  
From: **Mexico**

Email Cornerstone Brands Transportation: [routing@cornerstonebrands.com](mailto:routing@cornerstonebrands.com)

**Kingsgate Requirements**

Pickup requests should be submitted 48 working hours in advance of ready date. Daily cutoff is 2PM EST. Examples:

- i. Booking placed on Monday, 10AM. Earliest available pickup would be Wednesday of the same week.
- ii. Booking placed on Monday, 3PM. Earliest available pickup would be Thursday of the same week.
- iii. Booking placed on Friday, 10AM. Earliest available pickup would be Tuesday of the following week.

Kingsgate provides consolidation services for Cornerstone in Southern California and the NY/NJ area. Shipments from these areas are allowed up to **5** days consolidation time from ready date.

All other points are allowed up to **3** days consolidation time from ready date.

*As a result of the consolidation program, your shipment is not guaranteed to pickup on the ready date.*

Kingsgate will communicate date of pickup at least 24hrs in advance.

**Bill of Lading Requirements**

1. Bill of Lading must have ALL Purchase Order Numbers on it.
2. Carton and Skid Count must be listed on Bill of Lading. Carton count must match ASN.
3. Routing Authorization Number (if applicable) must be on Bill of Lading.
4. All full truckload shipments must have a seal placed on them with the seal number listed on the BOL.

**Please refer to the vendor compliance manual for ASN, packaging, labeling and all other requirements.**

**Routing guide is subject to change.**

**For the most up to date routing guide and vendor compliance manual please go to our web site at:**

<http://www.ccsqinc.com/>

**\*Failure to follow these routing instructions will result in a charge back penalty.\***

**\*Please see the vendor compliance manual for details.\***

The DC phone number to arrange delivery is (513) 603-1024.

**BILL OF LADING NEEDS TO READ “FREIGHT COLLECT”**

1. Bill of Lading MUST have all Purchase Order numbers on it. Example: P.O. #12345
2. Carton and Skid Count must be listed on Bill of Lading. Carton count must match ASN.
3. Routing Authorization Number (if applicable) must be on Bill of Lading.
4. Please write “Do Not Break Shrink Wrap” on the BOL and if possible on the label, skid or box.
5. ALL ORDERS MUST BE SHIPPED SECURELY ATTACHED TO A SKID.
6. Please indicate the Freight Class of product. If unsure, please contact the carrier for classification.
  - a. Apparel shipments must list one of the following National Motor Freight Classification item numbers on the Bill of Lading:

Clothing .....	#49880
Clothing Shipped on Hangers .....	#49880
Socks .....	#49940
Gloves or Mittens.....	#49910
Hats .....	#49880

**All freight-collect Less-Than-Truckload and Truckload shipments should list the freight bill-to as:**

TravelSmith Outfitters, c/o Cass Information Systems  
P.O. Box 6556  
Chelmsford, MA 01824-0942

**MANDATORY: CONSOLIDATE SAME DAY /DESTINATION**

All Merchandise to be shipped from a single shipping address to a single destination address on the same day must be combined onto a single Bill of Lading. Routing Guidelines should then be applied to the entire Shipment.

#### **FREIGHT CHARGE PAID BY VENDOR**

a. TravelSmith would prefer that our vendors use one of our house carriers in order to minimize carrier congestion at our receiving dock. [Freight on merchandise invoices will not be paid- must ship collect per routing guide.](#)

b. No C.O.D. shipments will be accepted.

c. Airfreight will not be allowed under any circumstances without prior authorization!

*\*At time of shipping, please make sure an Advanced Shipment Notification (ASN) has been sent via EDI, Vender Net, or Emailed Excel Spreadsheet. Faxed ASN's are not accepted. If you have any questions regarding your ASN, please call (513) 603-1023 or the Vendor Compliance Manager at (415) 798-3027.\**

*\*\*\*Deviations from these routing instructions that cause TravelSmith to incur additional costs will result in a chargeback of the entire freight plus an additional \$25.00 processing fee.\*\*\**

**USE OF INCORRECT CARRIER WILL RESULT IN SHIPMENT BEING CONSIDERED FOB DESTINATION, MAKING THE VENDOR LIABLE FOR ANY SHORTAGE OR DAMAGE THAT OCCURS IN TRANSIT.**

#### **IMPORT REQUIREMENTS**

The United States Customs Service was created to administer the trade laws of the U.S. Government and to collect duties and taxes on shipments of goods and baggage.

#### **DOCUMENTATION**

Entries are required by the Customs Service to accommodate the paying of duties and taxes that are due and payable to the U.S. Government at the time of importation. Duties are assessed when the importing carrier arrives at the U.S. port of entry. To facilitate the entry of goods into the United States, U.S. Customs officials require documentation provided to secure their release. Documentation must be provided within 5 working days from the date the carrier arrives. To successfully meet these requirements, TravelSmith requests the following documentation:

- a. Carrier's certificate, original bill of lading, or airway bill properly consigned
- b. Signed commercial invoice and packing list
- c. Detailed description of item in English
- d. Declare value of item (vendor's selling price) stated in U.S. dollar value
- e. Other cost of item (freight, insurance, etc.), if applicable
- f. Net quantity for each item
- g. Gross weight in kilograms
- h. Country of origin of the item

a. Case Labeling/Markings: The country of origin must be marked on the outside of the case. This can be on a label or directly on the cardboard.

a. Item Labels: each imported article to TravelSmith is required to be marked with the country of origin and fiber content and must appear in English. The markings are included on the sewn-in labels for textiles and securely affixed to hard goods.

a.

a.

a.

a.

a.

a.

a.

a.

**SPECIFICATIONS SPECIFIC TO IMPORT VENDORS**

- a. Packing slips must be ON and IN the lead case for each purchase order  
(Ex. Cases of the same PO should be numbered 0xx of xx0 starting with 01 of xx0, 1=lead case).
- b. Bill of Lading (BOL) and PRO# are supplied by the import vendor's freight forwarder.
- c. The carrier for an import vendor is their freight forwarder.
- d. The UCC-128 label bar code must meet the following specifications:
  - Minimum narrow element: .020 (.05cm)
  - Wide element: 1.00 (2.5cm)
  - Minimum Bar Height: 1.00 (2.5cm)
  - Maximum Pattern Length: 3.120 (7.9cm)
  - Overall Pattern Length: 3.520 (8.93)
- e. Cases must meet the following dimensions:
  - Minimum case weight is 2lbs. (.9kg)
  - Maximum case weight is 50lbs. (22.7kg)
- f. All items must be shipped against a valid Purchase Order.

**TRAVELSMITH INTERNATIONAL VENDOR ROUTING GUIDE**

Effective February 1, 2009

Consignee/Destination: TravelSmith, 8877 Union Centre Blvd, West Chester, OH 45069

Importer # 94-316433100

**Shipments originating from any country:**

<p><b><u>Dimensional Weight: 1 to 56 lbs (1 to 25 kilograms)</u></b>  <b>Carrier: UPS    Terms: Collect ó Account X03469</b>  <i>Please enter <b>Purchase Order Number</b> in the Reference Field.</i></p>
--

**Shipments originating from Canada or Mexico:**

<p><b><u>Dimensional Weight: 57 lbs and Greater (&gt;26 kg)</u></b>  <b>Carrier: Yellow Freight    Terms: Freight Collect ó No Account # Necessary</b>  <i>Please reference the <b>Purchase Order Number</b> on the BOL</i></p>
---

**Shipments originating from any of the countries below with a shipment weight > than 26 kg**

PHOENIX	EXPEDITORS
Country	Country

Austria	Taiwan	Qingdao, CN	Zhongshan, CN	Brazil		
Belgium	Chiwan, CN	Sanshan, CN	Philippines	Denmark	Portugal	
France	Dalian, CN	Shanghai, CN	Vietnam	Germany	Korea	
Hong Kong	Fuzhou, CN	Shekou, CN		Great Britain	Spain	
Indonesia	Guangzhou, CN	Shenzhen, CN		India	Turkey	
Poland	Huangpu, CN	Tianjin, CN		Israel		
Sweden	Jiangmen, CN	Xiamen, CN		Italy		
Switzerland	Nanhai, CN	Xingang, CN		Netherlands		
Sri Lanka	Nanjing, CN	Yantian, CN		Peru		
Indonesia	Ningbo, CN	Zhanjiang, CN				

Attn: China origin port/province shaded in gray

Attn: China origin port/province shaded in gray

<b>Forwarder/ Broker:</b> <b>Phoenix International</b> <b>Terms:</b> Freight Collect ó No account # Req.	<b>Forwarder/ Broker:</b> <b>Expeditors International</b> <b>Terms:</b> Freight CollectóNo account # Req.
Find your forwarder's origin office/contact at: <a href="http://ccsginc.com/travelsmith.htm">http://ccsginc.com/travelsmith.htm</a> clickö (Routing Guide Contacts)	Find your forwarder's origin office/contact at: <a href="http://ccsginc.com/travelsmith.htm">http://ccsginc.com/travelsmith.htm</a> clickö (Routing Guide Contacts)
Original <i>Customs paperwork</i> sent to -	
<b>Phoenix International</b> <b>Attn: Lisa Talmage</b> <b>855 IL Route 83</b> <b>Bensenville, IL 60106-1219</b> <b>Tel: (630) 274-7950 Ext - 17001</b>	<b>Expeditors International</b> <b>Attn: Michelle Redmon</b> <b>2000 Connor Road, Suite 190</b> <b>Hebron, KY 41048</b> <b>Tel: (859) 282-9494</b>

Copy of originals should be sent via email to [esimborg@travelsmith.com](mailto:esimborg@travelsmith.com) OR mailed to Accounting Dept., TravelSmith Outfitters, 60 Leveroni Court, Novato, CA 94949

*Please note that "Customs Paperwork" includes but is not limited to: Commercial Invoices, Packing list and original Bill of Lading (if applicable) plus any other customs required paperwork for specific commodities.*

**\* FOR VENDORS THAT SHIP INTERNATIONALLY, AND THE TERMS ARE FOB DOMESTIC, YOU MUST BREAK DOWN/DE-VAN YOUR SHIPMENT BEFORE CALLING FOR PICKUP. OUR APPROVED DOMESTIC CARRIERS ARE NOT EQUIPPED TO PICK UP FULL SHIPPING CONTAINERS.**

**WOOD PACKAGING MATERIAL**

On September 16, 2005, the U.S. Animal and Plant Health Inspection Service (AHPIS) will bring into effect their new regulations involving the importation of many types of wood packaging material such as pallets, crates, boxes, and dunnage.

Wood packaging material used in international trade will be required to be treated either by heat treatment or fumigation by use of methyl bromide. Such packaging material will be required to be marked as having undergone such treatment.

For additional information on the new regulation, requirements and certain exceptions to the requirements; such as, WPM entering the U.S. from Canada, please visit the AHPIS website directly at <http://www.aphis.usda.gov/>.

## ADVANCED SHIPMENT NOTIFICATION STANDARDS

TravelSmith requires an Advance Shipment Notification (ASN) for all shipments to our distribution center location. An ASN is case detailed information pertaining to your shipment. We require a consolidated ASN with case level information, as a minimum, for every shipment. Pallet level information is acceptable however, and must correspond to the case level information. It will include the UCC-128 carton barcode numbers, the TravelSmith SKU's, and carton quantities you are shipping. It must be 100% accurate. A packing slip *may not* be substituted for an ASN.

•Quantity refers to each's, not quantities of prepacks.

➔ The ASN must be received by our warehouse via email at least 24 hours prior to your shipment being received.

We offer two options to send the ASN that will accommodate any vendor:

VENDOR NET \* **WE STRONGLY RECOMMEND THIS OPTION** \*

Vendors not set up for EDI transmission have the alternative to use Vendor Net, a web-based supply chain collaboration program that is available for printing UCC-128 compliant labels and producing the associated ASN. You need internet access, Microsoft Word 2000 or better, a PC (not a Mac) and a printer for printing orders and carton labels. If you want more information regarding Vendor Net, please contact the Vendor Compliance manager at 415-798-3027. This program is free, is easy to use, and requires just 30 minutes for training and 30 days for set-up. Plus, you will greatly reduce the likelihood of chargebacks by using Vendor Net.

### EXCEL SPREADSHEET ASN

The third option is a free Excel macro spreadsheet, downloaded directly from our Vendor Compliance website: <http://ccsginc.com>.

Click on the TravelSmith Link, and when prompted for a username and password:

USERNAME: **travelvc**

PASSWORD: **tsmith2000**

Please note username and password are case sensitive and *must be lowercase*.

The spreadsheet contains instructions for filling out the appropriate information within. You need to have Excel 97 or better to access the spreadsheet.

1. Send all email addresses of those who might be emailing ASNs to [jmcafee@travelsmith.com](mailto:jmcafee@travelsmith.com). Without this advance notice, your emails will be treated as spam and will be discarded without being opened.
2. ASN spreadsheets should be completed and emailed as an attachment to [asn-tso@ccsginc.com](mailto:asn-tso@ccsginc.com), as well as copied to your inventory planner. Be sure you are using the most recent version of this spreadsheet, as older versions will not be accepted. It is advised that you visit our website every few months to ensure that the version you are using is the most current. In the subject line of the email, include the PO #(s) in the ASN.
3. Your ASN will be processed the day after it is received. A reply email is sent confirming that the ASN was received. \* **If you do not receive a reply email, it means that we did not actually receive your ASN (treated as spam and discarded) and you will be charged for a late ASN.** \*
4. \*Receipt of the ASN is not a guarantee that the ASN is accurate. If your ASN is incorrect, you will receive a chargeback even though you sent the ASN 24 hours in advance. \*

If you have not shipped to TravelSmith previously, please review our ASN procedures at least four weeks prior to the designated ship date on your purchase order.

**Use only ONE PO per ASN.  
1 ASN cannot be spread across multiple shipments.**

See example of ASN format utilizing UCC-128 bar codes on next page.

ASN SPECIFIC CONTENTS

Your ASN must be 100% accurate. In order to maintain accuracy, the scan and pack method of ship notice creation is recommended.

ASN notification, as shown on the following page, must include the following information:

- a. Vendor #, name, address, and contact name and phone # (must match PO exactly)
- b. PO #
- c. Date Shipped
- d. Expected delivery date
- e. Carrier
- f. Ship complete indication (Y/N)
- g. PRO # or Tracking #
- h. Total units shipped
- i. Total weight
- j. Total cartons shipped
- k. Case level information
- l. UCC-128 Case #
- m. TravelSmith SKU #
- n. Case quantity
- o. Item quantity

ASN CREATOR FORM:

To Download this form, please visit <http://ccsginc.com>

### PACKING SLIP CAPABILITIES

All shipments must be accompanied by a packing slip. Labels affixed to the outside of the cases do not constitute a packing slip.

The number of Packing Slips required depends on the method of shipment:

#### TRUCK LINE/CONTAINER

- Packing slip may be attached to the Bill of Lading (BOL).
- OR
- One packing slip externally attached on LEAD case for EACH PO (or on a carton that is clearly marked "Packing Slip Here.")

#### UPS/ALL OTHERS

- One packing slip externally attached on EACH case. (necessary because UPS does not always deliver all the cartons on the same day)
- 

#### PACKING SLIP SPECIFICS

Packing slip information (see format next page):

- |  |   |
|--|---|
| <ul style="list-style-type: none"> <li>a. Vendor name, address, phone, fax</li> <li>b. Bill To: TravelSmith + Address</li> <li>c. Ship To: TravelSmith + Address</li> <li>d. Carrier Used</li> </ul> | <ul style="list-style-type: none"> <li>h. Vendor Item #</li> <li>i. TravelSmith Item #</li> <li>j. Item Description (Qty, Size &amp; Color)</li> <li>k. Total # of Cases</li> </ul> |
|--|---|

- e. Ship Date
- f. Purchase Order #
- g. Carrier PRO #

- l. Total # of Units
- m. Total # of Pallets
- n. Weight of Shipment

**Import shipment packing slips should be ON AND IN the lead case for each PO.**

Sample Packing List: (vendor may use other formats)

<b>VENDOR NAME</b>		(short or long is OK)			
Street Address					
City, State, Zip Code					
Phone Number					
Fax Number					
<u>PACKING LIST</u>					
<b>BILL TO:</b>		<b>SHIP TO:</b>			
TravelSmith		TravelSmith Distribution Center			
60 Leveroni Court		8877 Union Centre Blvd.			
Novato, CA 94949		West Chester, OH 45069			
<b>CARRIER USED:</b>	<b>CARRIER PRO #:</b>	<b>SHIP DATE:</b>			
<b>PURCHASE ORDER #:</b>					
QTY ORDERED	QTY BACKORDERED	QTY SHIPPED	TravelSmith ITEM #	VENDOR ITEM #	DESCRIPTION (SIZE, COLOR, STYLE)
<b>TOTAL UNITS</b>	<b>TOTAL CARTONS</b>	<b>TOTAL PALLETS</b>	<b>TOTAL WEIGHT</b>		

**EXTERNAL CASE LABELING**

**EXTERNAL CASE LABELING –UCC-128 SERIAL SHIPPING CONTAINER LABEL (SSCC-18)**

The VICS Uniform Code Council 128 (UCC-128) standard case label is required. For more information, call (800) 543-8137 or [www.uc-council.org](http://www.uc-council.org). Individual Case Labels must be affixed to each shipped case.

- UCC 128 labels may be handwritten however; most handwritten labels typically have errors which result in chargebacks.

**CASE LABEL SUPPLIER**

Please contact ADI to obtain high quality, low cost labels:

Adaptive Data Interchange (ADI)  
 93 West Franklin Street  
 Centerville, OH 45459  
 Ph (937) 436-2343  
 Fax (937) 436-2344  
 Email: <mailto:jgribler@adi-barcode.com>

ADI can send labels that are as detailed as you want or they can send labels that are partially filled out. Or use Avery labels #5168 4x6 or thermal labels 3.75x 5.5.

**EXTERNAL CASE LABELING SPECIFIC CONTENTS**

Example case label:

Vendor name is all that is reqd; the address is optional

Use correct color abbreviation from PO

Include leading zeros

Add this if you have it. If UPS, use UPS Tracking #

Unique carton #

**EXTERNAL CASE LABELING FOR VENDOR NET**

Vendor Net labels print a little differently from a manual carton label; example:

<b>FROM:</b> Vendor Number	<b>TO:</b> TravelSmith Distribution Center 8777 Union Centre Blvd. West Chester, OH 45069
<b>SHIP TO POSTAL CODE</b>	<b>Carrier Info:</b> Use Routing Guide <b>BOL: Sample</b>
<b>Purchase Order #: TSO 000040011</b> <b>TravelSmith Item #: 12345 BLK MP</b>  <b>VENDOR ITEM#: PUG 969</b>  Vendor Desc: W KNIT WRAP TOP <b>Quantity: 12</b> <b>Carton: 1 of 6</b>	
SSCC #  (00) 0 0 0003214 0000440 2  	

**UCC-128 SHIPPING CASE LABEL DATA REQUIREMENTS:**

- a. Vendor Shipping Information (address)
- b. Ship-To Information (from PO)
- c. PRO # (optional)
- d. Bill of Lading (BOL) # (optional)
- e. TravelSmith Purchase Order (PO) #
- f. TravelSmith Item/Style #
- g. Vendor Item # (optional)
- h. TravelSmith Item Description (Size & Color)
- i. Quantity per Case
- j. UCC 128 Symbology (Case Identification Bar Code)
- k. Case Count (i.e. 01 of 05)
- l. Lot # (optional)

**GENERAL INFORMATION:**

- a. Shipping Case Label must appear on every case
- b. Recommended label dimensions:  
English: 6(H) x 4(W)

Metric: 15 cm(H) x 10cm(W)

- c. Type must be at least 3/16" (or 10 pt)
- d. Case Labels MUST be applied to the lower left corner of *short side* of the carton
- e. PRO #s may be requested in advance from issuing Shipping Company
- f. Low-reflective tape, if tape is used on the label

**EXTERNAL CASE LABELING SPECIFIC CHARACTERISTICS**

**UCC 128 SYMBOLOGY EXPLANATION:**

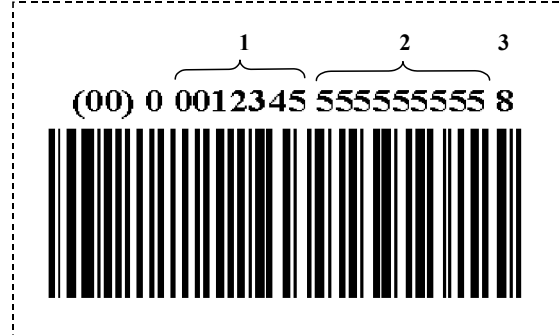

- 1) Vendor's UCC Number (or UPC preceded by a zero). Contact Vendor Relations Director if UCC numbers are not utilized
- 2) Unique Carton Identification Number (9 digits)
- 3) Check digit



- 1) Vendor's UCC Number (or UPC preceded by a zero). Contact Vendor Relations Coordinator if UCC numbers are not utilized
- 2) Unique Carton Identification Number (9 digits)
- 3) Check digit

**NOTE:** The Uniform Code Council has approved a standardized format for the UCC-128 Case Label. For more information, call (800) 543-8137 or [www.uc-council.org](http://www.uc-council.org).

This case label must have the UCC-128 bar code symbology.

The bar code must meet the following specifications:

- UCC Code 128 subset 0C0
- Encoded Digits: twenty- (20) numeric
- Minimum Narrow Element: .02"
- Wide Element: 1.0"
- Minimum Bar Height: 1.0"
- **Maximum Barcode Length: 3.12"**
- Overall Length including Quiet Zones: 3.52"
- The carton label must be unique to each carton; duplicate carton numbers will result in a chargeback.

A UCC-128 bar code quality program must be in place that ensures ANSI A or B print quality (ANSI X3.182). Be sure to use smudge-proof labeling/ink and low-reflective tape (if tape is used to apply the label).

Case Label Placement Explanation and Guidelines:

## Conveyables Labeling Guidelines

**Challenges-** Case must receive a usable scan and ride the conveyor securely. The scanner is pointed at the lower left-hand area of the approaching case. To ride securely, the center of gravity of the case must be as low and evenly balanced as possible.

**Requirements-** One UCC-128 case label must be placed on one of the smallest sides of the case. To do this, disregard what you may normally think is the height of the box. Find the two smallest measurements of the box. The smallest measurement will become your height and the next to the smallest measurement will be your width. Turn the box with this side facing you. Place the label upright, lower left-hand corner, 1 inch from the bottom and left edges of the case. If your height is smaller than 6 inches, you can wrap the top portion of the label over the top of the box. Case flaps should not effect label placement. However, do not cross a flap with a UCC barcode.

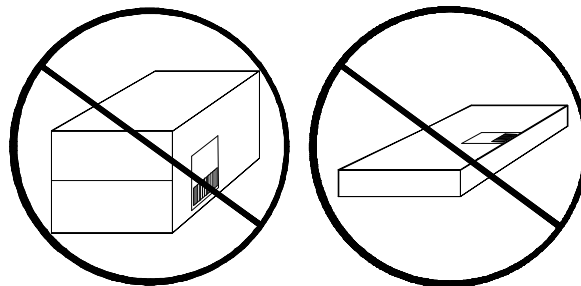
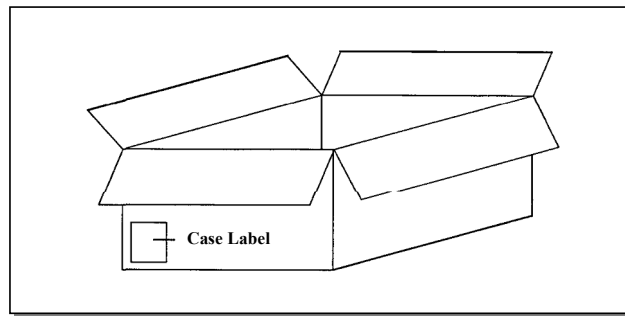
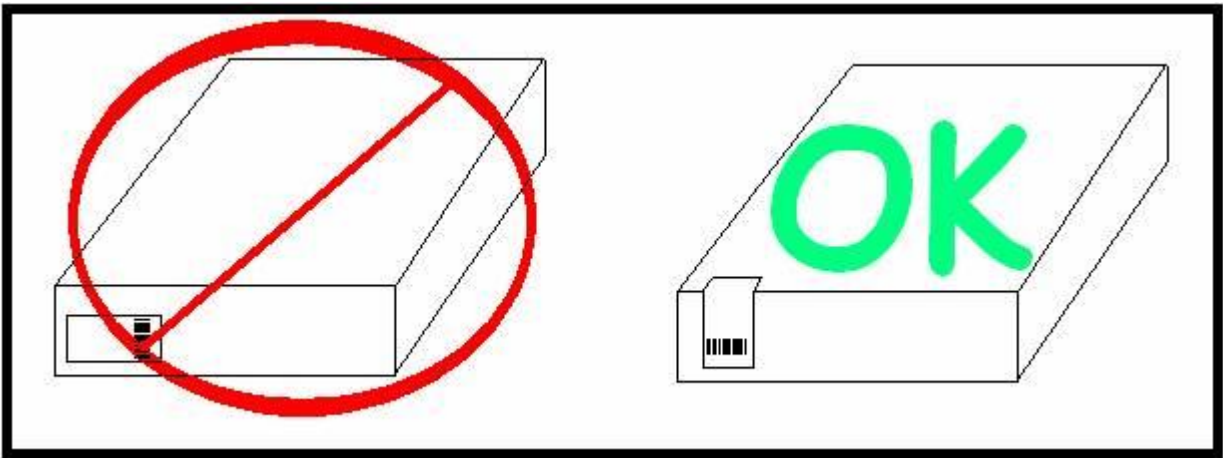

- ***Failure to place the carton label in the correct location will result in a Vendor Chargeback.***

All of the above requirements when it comes to carton labeling, sku labeling, packaging, ASNø, shipping,

etc can be completed by our third party partner for a fee.

Please contact **Judy Thomson** at [jthomson@kable.com](mailto:jthomson@kable.com).

**Kable Packaging**  
**4275 Thunderbird Lane**  
**Fairfield, OH 45014**  
**(Phone) 513-671-2800 ext 113 (Fax) 513-671-2830**

## **VI. PRODUCT SAFETY**

The Merchandising Department is responsible for ensuring compliance and minimizing product liability exposure. Your products must meet all federal and state product safety regulations, as well as any other applicable consumer protection statutes and regulations. To follow are some examples of Federal Trade Commission and Consumer Product Safety Commission federal regulations:

- Textile Fiber Products Identification Act
- Flammable Fabrics Act
- The Consumer Products Safety Act
- California's Proposition 65

## **VII. COMPLIANCE**

Prior to your first shipment of goods to TravelSmith, we require that specific documents be read, signed and returned as acknowledgement to their contents. The document describes in detail the contractual method with which we conduct business with our vendors.

## **TERMS AND CONDITIONS OF PURCHASE**

The terms and conditions of purchase are outlined on the TravelSmith purchase order. If you have any questions, please contact your Inventory Planner.

All purchase orders need to be reviewed by the vendor to confirm that ship dates, style number, colors, sizes, price, and credit terms are correct. An order confirmation needs to be sent to our office within three (3) business days after receipt of the purchase order. **Any discrepancies must be noted and communicated to the Inventory Planner immediately.**

TravelSmith expects all merchandise to be **shipped by the ship date requested on the purchase order**. All merchandise must be shipped on time. If your shipment is late, you are required to provide expedited shipping outlined in Section D below. You are also liable for one of the following penalties.

A 10% deduction on the total invoice value for the late purchase order.

### **OR**

A \$10.00 deduction per unit backordered until the shipment is received and passes quality assurance at our distribution center.

## **DELIVERY OPERATIONS**

A- Complete Shipments- each purchase order should be shipped complete as one delivery. In the event that a vendor is unable to ship an order complete by the specified ship date, a request for a partial shipment can be made by contacting the undersigned Inventory Planner prior to shipment.

Five (5) percent over/under requested purchase order per SKU may be accepted with advance notification to your Inventory Planner. Unauthorized variances are subject to chargeback penalties.

\*Acceptance of partial shipments is at the discretion of the Inventory Planner. If partial shipments are approved, the Inventory Planner may require that certain sizes and colors be prioritized.

B- Overages- If a vendor wishes to ship over and above the quantities set forth in the purchase order, the undersigned Inventory Planner should be contacted before the goods ship. Quantities shipped over the amount in the purchase order will not be accepted without prior approval. Any such quantities will be deducted from the invoice, and a return authorization will be requested. The returned merchandise will be shipped freight collect.

C- Early Deliveries- Merchandise may not be shipped prior to the requested ship date without prior consent of the Inventory Planner. In the event that merchandise is shipped without prior consent, the Inventory Planner has authority to return the merchandise at the vendor's expense or receive the merchandise. If the Inventory Planner elects to receive the merchandise early without prior consent, payment will be made according to the **original** expected receipt date, not the actual receipt date.

D- Late Deliveries- If an order is late, and will be shipped after the requested ship date, the Inventory Planner must be contacted immediately. A thorough explanation of the circumstances causing the delay should be communicated to the Inventory Planner via email. **Merchandise shipped after the requested ship date is subject to complete or partial cancellation by the Inventory Department.**

In addition, orders shipping late are subject to the following penalties:

- The vendor may be subject to paying the difference between air and sea freight charges when a late order designated to ship by sea must be expedited to air freight.
- The vendor may be required to cover the entire freight charges when an order scheduled for transport by air is late due to production delays.
- Domestic deliveries will be shipped via UPS 1 or 2 day (to be determined by the Inventory Planner) at the expense of the vendor.
- The vendor will be charged back at a rate of \$10.00/unit or 10% of the invoice for all merchandise that is back-ordered by our customers as a result of purchase orders shipping late from the agreed upon ship date.

TravelSmith expects all of our vendors to keep us informed of any shipping delays for any reason, including credit holds. Please contact our Accounts Payable and Inventory Planning Departments immediately if any potential credit problems arise.

➔ Merchandise not packed and shipped as specified in this manual will result in specified chargebacks.



# Purchase Order

REPRINT

Purchase Order No.

<b>Ship To:</b> TravelSmith 8877 Union Centre Blvd. West Chester, Ohio 45069	<b>Bill To:</b> TravelSmith - AP 773 San Marin Dr, Suite 2300 Novato, CA 94949
---	---

**Vendor#:**

Page 1 of 1

PO Date	Terms	Ship VIA	F.O.B.	Ship Date
---------	-------	----------	--------	-----------

**IMPORTANT:**  
Advance Ship Notice must be sent via an electronic transfer of data. Effective 4-1-04 fax will no longer be accepted. For additional information on options or to download an approved Excel program please see our website <http://www.ccspline.com> or e-mail us at [asn-tso@ccspline.com](mailto:asn-tso@ccspline.com).  
1) Cartons and contents must be labeled, packed and shipped according to the TS vendor compliance guidelines. For more details go to: <http://ccspline.com> or call your planner.  
2) All shipments are required to have TravelSmith's PO number and TravelSmith's Sku number on all invoices, packing slips, and master cartons.  
3) All bills of lading must show TravelSmith's PO number and the following statement:  
"Carrier- Please call 513-603-1024 to schedule delivery appointment".

**Special Instructions:**  
PLEASE USE TS ITEM # ON ALL LABELS AND DOCUMENTS  
SHIP PER PARTNERSHIP MANUAL AND CONFIRM PO RECEIPT  
THANK YOU.

TravelSmith Item Number	Vendor Model Number	Description	Qty	Unit Price	Ext. Amount
<b>Purchase Order Total</b>					

**X** Signature indicates full acknowledgement of PO and agreement to order terms and conditions  
This Purchase Order (PO) is given only as a supplement to the Terms and Conditions for Purchase Orders with TSO (T&Cs), and is not solely a valid commitment on the part of TSO to acquire goods or services. By accepting this offer, Seller represents and acknowledges that Seller has executed, and agrees to abide by the terms of the T&Cs. If no such agreement exists between parties, this PO is deemed unenforceable. In the event of conflicting terms between this PO and the T&Cs, the following conflict resolution hierarchy shall apply: (1) the PO shall prevail in all matters relating to payment terms; (2) the T&Cs shall prevail in all other matters. Any communications between Seller and TSO, whether verbal, written, or otherwise (including, but not limited to, in-person or telephonic meetings, letters, e-mails, text messages and any other form of communication), which are not evidenced by a PO shall be considered only in-progress negotiation of terms of purchase and shall not be construed as a binding commitment on either party. Any costs incurred by either party, including the manufacture or acquisition of goods by Seller prior to the receipt and acceptance of a PO will be at the incurring party's risk and TSO shall have no obligation to pay for unavoidable, out-of-pocket costs incurred by Seller. Any additional or different terms other than the foregoing that may be proposed by Seller are hereby rejected and invalid.

## TERMS AND CONDITIONS FOR PURCHASE ORDERS

**ALL PURCHASE ORDERS ISSUED BY TRAVELSMITH OUTFITTERS, INC (“TSO”) TO THE UNDERSIGNED SELLER (“YOU,” “YOUR”) ARE SUBJECT TO THE FOLLOWING TERMS AND CONDITIONS (“T&Cs”):**

1. **Description of Products; QA Procedures.** All Products purchased from You by TSO (öProductsö) pursuant to a purchase order (öPOö) will conform to the samples and other descriptions provided to TSO. You will comply with all of TSO’s quality assurance and fulfillment policies, standards, and procedures, including those contained in TSO’s most current Vendor Compliance Manual (öVCMö). Any costs or expenses You incur as a result of commencing production of Products prior to obtaining the written approval of TSO’s quality assurance department of requisite sample(s) of the Products, or as a result of Your efforts to satisfy TSO’s procedures, standards or requirements, are Your sole responsibility. In addition to Your submission of QA samples, any other samples that You provide to TSO, including any öBuyerö samples, will become the property of TSO and will not be returned to You, unless otherwise specified.

2. **Shipment; Delivery.** Time is of the essence with regard to the shipment of Products. Unless otherwise mutually agreed in advance in writing, You will ship the Products to TSO not later than the shipping date set forth on the applicable PO. The Products will be shipped in accordance with the PO (or if no instructions in the PO, the Products are to be packaged, shipped and routed in accordance with the VCM), unless otherwise authorized by TSO. You will indicate TSO’s PO number on all invoices, packages and other communications with TSO. You will immediately notify TSO if You are unable to ship all or any portion of the Products by the ship date specified in the PO or as otherwise authorized by TSO. Any POs that are not shipped by the ship date specified on the PO and for which TSO has not authorized any other ship date may be canceled by TSO and/or penalties and chargebacks may result as set forth in the VCM. If Your acts or omissions result in Your failure to meet TSO’s delivery schedules and requirements and TSO requires a more expeditious method of transportation for the Products than the transportation method originally specified by TSO, You shall, at TSO’s option, (a) promptly reimburse TSO the difference in cost between the more expeditious method and the original method, (b) allow TSO to reduce its payment of Your invoices by such differences, or (c) ship the Products as expeditiously as possible at Your expense and invoice TSO for the amount which TSO would have paid for normal shipment. Unless otherwise specified on the PO, all öDomestic Productsö (e.g., Products purchased by TSO which are picked up by TSO’s carrier within the continental United States) shall be delivered on a FOB TSO’s Place of Destination/Warehouse, Freight Collect basis. Notwithstanding such delivery, title and risk of loss or damage to Domestic Products will not pass to TSO until the Products are received at TSO’s distribution center or place of business. Unless otherwise specified on the PO, all öInternational Productsö (e.g., Products purchased by TSO which are picked up by TSO’s steamship/ocean carrier at an origin port outside the United States) shall be delivered on a FOB Origin, or as otherwise specified on the PO. Title and risk of loss and damage to International Products will pass to TSO in accordance with the freight terms on the applicable PO. You will provide TSO, at Your expense, all assistance and documentation requested by TSO for clearing the International Products through applicable customs agencies throughout the world.

3. **Inspection and Acceptance.** TSO or TSO’s authorized agent shall have the right to enter Your production facilities at reasonable times to inspect the facilities, goods, materials and any property of TSO covered by this PO. TSO’s inspection, whether during manufacture or storage, prior to shipment or after delivery, shall not constitute acceptance. Notwithstanding any prior inspection or payments, all Products will be subject to final inspection and acceptance or rejection at TSO’s distribution center or place of business within a reasonable time after delivery. TSO may reject any damaged, defective or non-conforming Products, or Products which otherwise do not conform to approved samples and specifications for color,

style, fit, packaging, labeling, materials, design, and construction. Products that are damaged, defective, or non-conforming may be returned and charged back to You. Additionally, TSO may choose, at Your risk and expense, to either hold such damaged, defective, or non-conforming Products pending Your instruction or return ship them to You, at Your risk and expense, at the address shown on the applicable PO.

4. **Payment.** Payment will be made in accordance with the terms shown on the face of the PO, based on the actual Products received. TSO reserves the right to hold payment on those Products shipped early without preauthorization and in such case the payment terms as stated on the PO will still apply. All invoices will clearly reference the shipment date, PO number, and any applicable Product number(s). If You instruct TSO to pay a third party, You will remain obligated to TSO under this "Agreement" (as defined in Paragraph 13, below). You will immediately pay any debit balance owed to TSO if TSO demands payment, or if such debit balance is outstanding for more than forty-five (45) days from the date of the occurrence giving rise to the debit balance. All of Your monetary claims are subject to set off by TSO for any claim or counterclaim of TSO. As reasonably requested from time to time, You will provide TSO with a statement showing any amounts due to or owed by TSO.

5. **Returns.** TSO will have the right to return products at any time with a valid reason, in its sole discretion, to return all or any portion of the Products to You. TSO's resale of any Product will not constitute a bar or waiver of TSO's right to return Products under this Paragraph 5. Title and risk of loss to any Products to be returned to You pursuant to this Paragraph 5 will pass to You upon TSO's delivery of the Products to a common carrier for return to You. TSO will pay all freight charges incidental to the return of any Products returned under this Paragraph 5 to Your place of business or point of shipment. You will fully and immediately refund to TSO any and all payments made for Products returned by TSO to You under this Paragraph 5. You shall reimburse TSO for all administrative expenses and lost profits associated with back orders or order cancellations due to rejection of Product, late delivery or delivery of insufficient quantities. If You do not authorize the return of Product, within ten (10) days after TSO gives notice of its intent to return the Product, TSO may return such Product without authorization. If You do not authorize the return of Product within such ten (10) day period, or refuse to accept any returned Product, TSO may dispose of such Product in any manner and deduct from the proceeds thereof all losses, damages, claims, costs and expenses incurred by TSO in connection with such Product. In addition, TSO retains its right to pursue all other remedies available to it under the law or in equity. You shall not sell or otherwise transfer any returned Product, seconds or overruns which bear TSO private labels, trademarks, service marks, trade names, logos, designs, hang tags or packaging to third parties unless all such TSO indicia have been completely removed or obliterated from each and every article of Product and packaging and then in the context of such disposition no reference shall be made to TSO and such disposition shall not occur in a market where TSO competes. You will not resell any returned Products with TSO labels, nor will You sell any returned Products with TSO labels removed. You acknowledge that TSO does not inspect each item of Product at receipt of merchandise and therefore You understand that damages or imperfections or failure to meet specifications (including, but not limited to, compliance with any and all laws and governmental regulations), may not be discovered by TSO until after they are purchased by the ultimate customer and returned by TSO after customer uses or closely examines their purchase. Authorization is expressly granted by TSO to allow such returns, in the sole opinion of TSO at any time, to be made for credit (or cash if TSO is not currently doing business with You). Request by TSO for return authorization shall not be denied by You.

6. **Representations and Warranties.** You represent and warrant to TSO that: (i) all information You provide to TSO is and will be true and correct; (ii) Your entering into these T&Cs and the performance of Your obligations hereunder will not conflict with or be prohibited or restricted by any agreements or commitments with third parties; (iii) title to Products delivered to TSO will be free of all liens, claims, debts, and rights of third parties; (iv) the Products are and will be genuine and not adulterated, misbranded, or mislabeled; (v) the Products will not infringe upon any "Intangible Rights" (as defined below), and You are

the owner of, or are licensed to authorize TSO to use, any and all Intangible Rights associated with the Products; (vi) the Products (and all components of the Products) will not be subject to any import quota, restriction, rule or regulation preventing the importation or sale of the Products or any component thereof; (vii) the Products will be new and not used, remanufactured, or reconditioned (unless otherwise mutually agreed upon), of consistent kind and quality, and free from all defects in material and workmanship; (viii) the Products will be safe and appropriate for the purpose for which Products of that kind are normally used; (ix) all manufacturers' warranties are completely transferable, effective, and enforceable by the ultimate consumer; (x) the Products and all materials provided to TSO in connection with the marketing, promotion, distribution, and sale of such Products, including, without limitation, packaging, labeling, and advertising materials for such Products, have been produced in compliance with all applicable federal, state and local laws, regulations, rules, guidelines, ordinances and standards (Legal Requirements), including, without limitation, laws relating to discrimination, coercion, harassment, health and safety, compensation, the environment, and use of child labor, in all locations throughout the Territory (as defined below) where the Products may be sold, and neither the Products nor their purchase or sale by TSO will violate any such Legal Requirements; (xi) the genuine origin of the Products will be stated on the Country of Origin Declaration, Invoice, Visa and other importation documents, and no shipment will be illegally transshipped from any other country; (xii) the Products have been manufactured in compliance with TSO's Code of Conduct for Manufacturers attached hereto as Exhibit A and incorporated herein by reference and (xiii) except as disclosed to TSO in writing, the Products have not been subject to any Products liability claims. The term Intangible Rights means any United States or foreign patents or copyrights or any United States, foreign, state or common law trademark, trade dress, trade name, service mark, publicity or privacy right or similar property or other right. You represent, warrant, and agree that the Products may be re-sold by TSO and its affiliates in any location in which TSO and/or its affiliates market, sell, or distribute Products and/or services (the Territory). These representations and warranties are in addition to and without prejudice to all other warranties expressed or implied by law. TSO has specifically relied upon all of Your representations and warranties contained in these T&Cs, and TSO will continue such reliance in purchasing Products from You as if such representations and warranties were made on the date of purchase of such Products. All of Your representations and warranties, both express and implied, will constitute conditions of sale, and will survive receipt, inspection, testing, acceptance, payment and use of the Products. You will fulfill Your warranty and other obligations to end use consumers and will be responsible for any product liability claims that arise from Products that You have supplied to customers.

7. **Indemnity.** You will assume full responsibility and will provide independent legal counsel reasonably acceptable to TSO for the defense of any claims, threatened actions, filed actions, suits, investigations or proceedings (Claims) that may be brought against TSO or its affiliates, officers, employees, agents or assignees by reason or as a result of or relating to: (i) any actual or alleged violation or breach by You of any of Your representations, warranties, covenants, or other obligations set forth in these T&Cs or in the VCM; (ii) any actual or alleged infringement of any Intangible Rights or any actual or alleged unfair competition; (iii) any claim, representation or statement made in connection with advertising or promoting the sale of the Products by any of Your employees or agents or by any celebrity or other person provided or made available by You who is not an employee of TSO, or, to the extent consistent with or substantially based on information or materials provided by You, any claim, representation or statement made in connection with advertising or promoting the sale of the Products by any person whatsoever; (iv) any actual or alleged death of or injury to any person, damage to any property, or any other damage or loss, by whomsoever suffered, resulting or claimed to result in whole or in part from any actual or alleged defect in the Products, whether latent or patent, or the failure of such Products to comply with any express or implied warranties; and/or (v) any actual or alleged violation by the Products or their manufacture, possession, use or sale, of any law, statute or ordinance or any governmental order, rule or regulation. You will indemnify, defend and hold TSO and its affiliates, officers, employees, agents and assignees harmless from and against any and all liabilities, injuries, damages, settlements, royalties, penalties, fines and other losses of every kind and nature whatsoever, including without limitation all attorney fees and other Costs

and expenses, incurred by or imposed upon them as a result of or in connection with any such Claims, or as a result of or in connection with any recalls of Products, whether voluntary or involuntary, or any actions taken to comply with all laws, regulations, rules, guidelines, ordinances and standards governing the safety, labeling, advertising or invoicing of Products, or any actual or alleged failure to comply with any bulk sales law or similar law for the protection of creditors. No settlement of any such Claims may be made without TSO's prior written consent to the terms of settlement. TSO will have the right to participate in the defense of any such Claim at its own expense. If TSO notifies You of a Claim to which the foregoing indemnification obligation applies ("Claim Notice"), You shall provide prompt assurance of Your ability and intent to indemnify TSO, to TSO's reasonable satisfaction, and You shall commence to defend such Claim, at Your sole cost and expense, within five (5) days of said Claim Notice. If You fail to provide such assurance or fail to commence such defense within said five (5) day period, in addition to the other rights and remedies available to TSO at law or in equity, TSO may, at its option, assume the defense or settlement of such Claim in its own name, and all recoveries from such Claim shall belong to TSO, and all fees and Costs (including reasonable attorney fees) in defending such Claim, and all damages or settlement Costs arising therefrom, shall be Your sole responsibility.

**8. Confidentiality.** You will not advertise or publish the fact that TSO has contracted to purchase Products from You, and will not disclose any information relating to these T&Cs to any third party. You will treat all information furnished by TSO, its parent, subsidiary, and affiliated companies as confidential, property of TSO and will not disclose any such information to any third party, or use such information for any purpose other than performing Your obligations under these T&Cs, except that You may disclose such information solely: (i) to Your employees, accountants, independent contractors, agents, and attorneys on a need-to-know basis, provided the recipient of such information has executed appropriate written agreements to ensure the confidentiality of such information consistent with these T&Cs; and (ii) under the terms of a subpoena or order issued by a court of competent jurisdiction or under a civil investigative demand or similar process, provided You agree (a) to promptly notify TSO of the existence, terms, and circumstances surrounding such a request, and (b) if You are, in the opinion of Your counsel, compelled to disclose a portion of such information, You disclose only that portion of the information that Your counsel advises that You are compelled to disclose, and will exercise reasonable efforts to obtain assurance that confidential treatment will be accorded to such information. You will treat all information obtained from customers as confidential and will not disclose any such information to any third party, or use such information itself for any purpose other than performing Your obligations to TSO. Specifically, but without limitation, You will not use any information obtained from TSO or customers to offer for sale to such customers any Products or services. You will not issue any press or publicity release or statement relating to TSO, any of its affiliates or operations, or these T&Cs without the prior written approval of TSO. You acknowledge and agree that any communication between counsel for You and TSO, or between You or TSO or any of their principals, employees, contractors or representatives, and Your counsel or TSO is protected by all applicable privileges, including without limitation the attorney-client, work product and joint defense privileges. You will not waive any such privilege without the express written consent of TSO.

**9. Standards of Conduct; Taxes; Customs.**

a. You will comply with all standards of conduct published and made available to You from time to time by TSO and will promptly disclose in writing to TSO any conflicts of interest or any circumstances that are inconsistent with or constitute a violation of the terms or spirit of such standards. Furthermore, You acknowledge and agree that there is a common interest between You and TSO in advertising claims relating to the Products, and in ensuring that all such claims are in compliance with all laws, government rules, and regulations regarding deceptive advertising and substantiation of advertising claims. Without TSO's prior written approval, You will not include Your address, telephone number, web site address, or other contact information in any packaging or labeling of the Products for the purpose of marketing or promoting any Products or services, other than customer or technical assistance services.

b. Any present or future sales, use, privilege, occupation, excise, value-added or other tax, fees or charges of any nature whatsoever imposed by any governmental authority on the transaction set forth in this PO shall be paid by You. No such taxes, charges, fees, etc. shall be paid by You on behalf of TSO without TSO's prior written consent. In the event that TSO is required to pay any such taxes, fees or charges, You shall reimburse TSO therefore.

c. You warrant and represent that You understand the United States Rules of Origin as set forth in Part 102 of the United States Customs Regulations and that its textile origin declaration, if applicable, will accurately and completely set forth the processes performed in each country and the source of all fabric and trim. You will not enter into any arrangement with any third party for the manufacture or sub-assembly of any International Products supplied to TSO without prior written notice to TSO. In order to maintain TSO's high standard of quality control and to ensure that appropriate measures are taken against counterfeiting, such notice will include the following information: (i) name and address of each manufacturer; (ii) type and style of the Products to be manufactured; (iii) quantity of the Products to be manufactured; and (iv) any other relevant information. You acknowledge that You will remain primarily liable and completely obligated under all of the provisions of these T&Cs in respect of any such subcontracting arrangement.

**10. Most Favored Nations; Exclusivity; Non-Compete; Non-Solicitation.**

a. All of the prices, terms or benefits granted by You for any Products purchased by TSO under this Agreement are equal or better than the prices, terms or benefits being offered by You to any present commercial customer for the same or comparable product ordered in the same or comparable quantities. If during the term of this Agreement You enter into an arrangement with any other company for the same or comparable product ordered in the same or comparable quantities providing greater benefits of more favorable pricing or terms, You shall promptly notify TSO in writing and then with respect to any open PO through date of delivery and any subsequent PO issued by TSO and accepted by You shall, at TSO's option, automatically be deemed amended to provide the same benefits or pricing to TSO.

b. Any Products developed for TSO by You under this Agreement will be made exclusively for TSO for a minimum of one (1) year so long as the Product is not otherwise available in the U.S. marketplace. Notwithstanding anything contained in the Agreement to the contrary, all product designs, design process, artwork and all other proprietary information of TSO furnished to You by TSO must be used exclusively for Products supplied to TSO and to no third party and You acquire no rights, title or interest in the foregoing. For purposes of clarification, ongoing POs may not be available for a period of one (1) year after completion.

c. You agree that for a period of six (6) months after Your sale of Products to TSO, You will not, directly or indirectly, sell substantially similar Products by means of a direct mail catalog, or its associated website(s), other than TSO.

d. For a period of one (1) year after each PO issued by TSO to You, You will not solicit for employment (other than a general, publicly disseminated solicitation for employment) or offer to employ any employee of TSO.

**11. Insurance.** You have and will keep in effect for five (5) years from the date of Your receipt of the first PO issued by TSO, full general/Products liability insurance coverage in amounts not less than those required by Your "Insurance Class," as determined by TSO's risk management department ("TSO Risk Management"). In addition if: 1) You are offering any services; 2) You have had any product recalled; 3) TSO determines, in its reasonable discretion, that the Products are subject to a license or are otherwise specifically warranted by an Your individual circumstances, including, but not limited to, prior losses or

claims history, whether with TSO or otherwise, You will also be required to provide \$2,000,000 Errors & Omissions (or its equivalent) per occurrence and in the aggregate. All insurance required by TSO Risk Management must: (i) be maintained with an Insurance Company rated by A. M. Best as "A" or better; (ii) name TSO, its direct and indirect parents, subsidiaries, affiliates, and assigns as Additional Insured; and (iii) be submitted with a copy of Your Broad Form Endorsement or the complete policy (or policies), in the English language. You must also provide the name of a specific person (including mailing address, phone and fax numbers, and email address) who is in charge of responding to complaints, claims, and/or lawsuits. All of these Insurance Requirements must be demonstrated by submission of one or more Certificates of Insurance sent to the attention of VP, Inventory Management at TravelSmith Outfitters, Inc. 773 San Marin Drive, Suite 2300 Novato, CA 94945 promptly following Your execution of these T&Cs, and no less frequently than annually thereafter upon the anniversary date of the applicable policy. These Insurance Requirements may be satisfied through a combination of primary, umbrella, or excess liability insurance policies. TSO Risk Management may, at its sole discretion, change the coverage limits and/or types of coverage required at any time.

**12. Relationship of Parties.** It is expressly acknowledged by the parties hereto that Your relationship to TSO under this Agreement is that of an independent contractor and nothing in this Agreement is intended or shall be construed to create an employer/employee relationship, or a joint venture relationship. You understand and agree that TSO will not withhold on behalf of You pursuant to this Agreement any sums for income tax, unemployment insurance, social security, or any other withholding pursuant to any law or requirement of any governmental body relating to You or make available to You any of the benefits afforded to TSO's employees and that all such payments, withholding, and benefits, if any, are Your sole responsibility.

**13. Entire Agreement; Amendment; Assignment.** These T&Cs and any other documents referred to herein constitute the entire agreement (collectively, the "Agreement") between You and TSO. This Agreement will be effective for all Products. You accept and agree to be bound by the Agreement by shipping Products. This Agreement sets forth the entire understanding and agreement of the parties with respect to the matter covered herein, superseding all prior and contemporaneous understandings and agreements, whether oral or written. This Agreement may not be modified or amended except by a written instrument executed by both parties, and each shipment received by customers will be deemed to be only upon the terms and conditions contained in this Agreement, notwithstanding any terms and conditions that may be contained in any of Your acknowledgements, invoices or other forms and notwithstanding TSO's or its customers' act of accepting or paying for any shipment or similar act of TSO or its customers. TSO has the right to assign this Agreement, or all or any portion(s) of its rights and/or obligations hereunder, including, without limitation, the right to purchase, market and sell the Products, to any company directly or indirectly controlling, controlled by, or under common control with TSO, and this Agreement shall inure to the benefit of any such assigns. You may not assign any rights, obligations, and/or or claims under this Agreement without TSO's prior written consent, and any attempted assignment without consent will be void.

**14. Governing Law; Jurisdiction.** This Agreement, and the legal relationship between You and TSO will be governed by California law, without regard to conflicts of law principles [and without reference to the United Nations Convention on Contracts for the International Sale of Goods](#). Any legal action or proceeding with respect to this Agreement may be brought only in the courts of the United States District Court for the Central District of California and the Superior and Municipal Courts located in Los Angeles, California, and each party hereby accepts the jurisdiction of such courts. You hereby irrevocably waive any objection, including, without limitation, any objection to the laying of venue or based on the grounds of forum non conveniens, which You may now or hereafter have to the bringing of any such action or proceeding in such respective jurisdictions. If any litigation is commenced to enforce any provision of this Agreement or to seek a declaration of the rights of the parties hereunder or as a result of any breach or

threatened breach of any provision of this Agreement, the prevailing party will be entitled to recover from the non-prevailing party all of its costs and expenses incurred in connection with such litigation, including without limitation reasonable attorneys' fees, at both the trial and appellate levels.

**15. Notice.** All notices or other communications required or permitted under this Agreement must be in writing, addressed to the address written below or to such other address for a party set forth in a notice given to the other party, sent to the intended recipient by prepaid registered mail, receipted commercial courier, or electronically receipted facsimile transmission, and will be effective upon delivery to the intended recipient. All communications to TSO shall be sent to the attention of VP, Inventory Management at TravelSmith Outfitters, Inc. 773 San Marin Drive, Suite 2300 Novato, CA 94945.

**16. Termination.** Either party may prospectively terminate the Agreement by giving the other party written notice of termination, which notice specifies an effective date of termination that is not less than thirty (30) days after notice is actually received by the non-terminating party (unless otherwise agreed to in writing by the parties), in which event this Agreement will terminate as to all Products not ordered prior to such effective date. After the effective date of such termination, all Paragraphs hereunder concerning the parties' rights and obligations which by the content of the Paragraph operate after termination (e.g., Your returns obligations) or which are necessary to enforce any right will survive any termination or expiration of this Agreement.

**17. Force Majeure.** Neither party shall be responsible for failure or delay of performance if caused by: an act of war, hostility, or sabotage; act of God; flood, hurricane, or other natural disaster; electrical, internet, software, telecommunication, or other systemic outage that is not caused by the obligated party; government restrictions; or other unforeseeable event outside the reasonable control of the obligated party (collectively, "Force Majeure Event"). Both parties will use reasonable efforts to mitigate the effect of a Force Majeure Event. Only if such event continues for more than forty-five (45) days, either party may cancel a PO or any other unperformed services upon written notice to the other. This Paragraph does not excuse either party's obligation to take reasonable steps to follow its normal disaster recovery procedures.

**18. Chargeback Policy**

As a supplier to TravelSmith, it is important that you comply with all of our product and packaging policies standards. Noncompliance with any of the procedures or standards will result in a chargeback, issued to you for the extra operational expense incurred by our Distribution Center. Charges will be determined for each violation and will be billed at \$50.00 per hour. There will be a \$100.00 fee added for each occurrence. You will be notified of any infraction and expected to correct the situation with future shipments.

**If you fail to correct the occurrence for your next shipment, you will be billed \$200.00.** The TravelSmith Accounting Department will be notified of the incident and a debit will be taken on your next invoice.

Note: Below is a quick reference chart of frequently incurred chargebacks. Any issue not in compliance with our Company Policies and Procedures outlined in this manual is subject to a chargeback.

<b>ITEM</b>	<b>ASSESSMENT</b>	<b>2<sup>ND</sup> OFFENSE</b>
Accurate & Complete Case Level ASN not received at Distribution Center 24 hours prior to receipt of shipment. ASN not sent via EDI, Vendor Net, emailed Excel Spreadsheet.	\$100 + \$50/hour to resolve/correct	\$200 + \$50/hour to resolve/correct
Purchase Order/ASN Discrepancies, duplicate UCC Case numbers used on ASN.	\$100 + \$50/hour to resolve/correct	\$200 + \$50/hour to resolve/correct
Minimum Case Markings not Present (TS SKU, PO #, QTY)	\$100 + \$50/hour to resolve/correct	\$200 + \$50/hour to resolve/correct

Inadequate UCC-128 case labels - including wrong location, non-compliant bar code, missing information.	\$100 + \$50/hour to resolve/correct	\$200 + \$50/hour to resolve/correct
Missing packing slip, packing slips not placed correctly, or missing case designation "Packing Slip Enclosed".	\$100/Purchase Order	\$200/Purchase Order
Shipping more than the number of POs indicated on BOL. Failed to consolidate same day/ destination shipments on one BOL.	\$100/Bill of Lading	\$200/Bill of Lading
Not listing case numbers of a multiple case shipment (e.g. 1 of 4).	\$100/Purchase Order	\$200/Purchase Order
Use of unauthorized carrier.	\$100.00 plus difference in freight.	\$200.00 plus difference in freight.
No Delivery Appointment or Cases not Palletized	\$100/Shipment	\$200/Shipment
Unauthorized air freight.	100% of freight bill	100% of freight bill
Shipping incorrect freight class.	\$100 plus difference in freight cost	\$200 plus difference in freight cost
Receipt of merchandise not covered on the Purchase Order.	RTV ó Vendor pays freight inbound and outbound.	RTV ó Vendor pays freight inbound and outbound.
Merchandise received past cancel date may not be accepted.	RTV at Inventory Planner's discretion. Vendor pays freight inbound and outbound.	RTV at Inventory Planner's discretion. Vendor pays freight inbound and outbound.
Over shipment or duplicate shipments not authorized.	RTV at Inventory Planner's discretion. Vendor pays freight inbound and outbound.	RTV at Inventory Planner's discretion. Vendor pays freight inbound and outbound.
Canceled Purchase Order will not be accepted.	RTV ó Vendor pays freight inbound and outbound.	RTV ó Vendor pays freight inbound and outbound.
Item sku, content, garment or gear labels missing or incorrect / Product incorrectly Packaged.	\$100 + \$50/hour to resolve/correct.	\$200 + \$50/hour to resolve/correct.
Early/late deliveries received without prior Inventory Planning approval.	Refer to Page VII. 1 of Vendor Manual	Refer to Page VII. 1 of Vendor Manual
Increased (up to 100%) quality inspections for QC problems discovered at TravelSmith Outfitters.	\$100 + cost per sku to resolve/correct. Possible RTV & freight costs for vendor resolution.	\$200 + cost per sku to resolve/correct. Possible RTV & freight costs for vendor resolution.
Multi-Sku Cases / Product Incorrectly Packed	\$5/case + labor & supply cost to re-pack & re-label.	\$5/case + labor & supply cost to re-pack & re-label.
Missing TOP samples	\$100 per PO	\$200 per PO
Banded Cartons / Carton Size outside of allowed range.	\$100 + \$50/hour to resolve/correct.	\$200 + \$50/hour to resolve/correct.
Style or color substitution without prior TravelSmith Outfitters approval.	Not accepted. Vendor pays freight inbound and outbound.	Not accepted. Vendor pays freight inbound and outbound.

## **RETURN TO VENDOR POLICY**

TravelSmith reserves the right to return to the vendor all merchandise that has been rejected in our quality assurance inspection process that is not in compliance with our packaging, labeling, product specifications or quality standards. This policy also applies to customer returns with manufacturing defects.

If your company requires an authorization number for us to return product to you, an Inventory Planning Representative will contact you for an authorization number.

**IF AN AUTHORIZATION NUMBER IS NOT RECEIVED WITHIN 30 CALENDAR DAYS, TRAVELSMITH WILL LIQUIDATE THE MERCHANDISE. YOUR ACCOUNT WILL BE DEBITED FOR THE COST OF THE LIQUIDATED MERCHANDISE.**

**19. Miscellaneous.** Each party acknowledges and agrees that any failure on the part of the other party to enforce at any time, or for any period of time, any of the provisions of this Agreement will not be deemed or construed to be a waiver of such provisions or of the right of said party to thereafter enforce each and every such provision. The headings and sub-headings used in this Agreement are for convenience only and are not a part of this Agreement. If any provision of this Agreement is declared null, void or otherwise unenforceable, such provision will be deemed to have been severed from this Agreement, which will otherwise be and remain in full force and effect according to its remaining terms; provided, however, that both parties shall negotiate in good faith with respect to an equitable modification of the paragraph, subparagraph or provision held to be invalid and provisions logically related thereto. Any specific right or remedy provided in this Agreement will not be exclusive but will be cumulative upon all other rights and remedies set forth herein and allowed or allowable under law. All Paragraphs hereunder concerning the parties' rights and obligations which by the content of the Paragraph operate after termination (e.g., returns obligations) or which are necessary to enforce any right will survive any termination or expiration of this Agreement.

## **EXHIBIT A**

### **TSO CODE OF CONDUCT FOR MANUFACTURERS**

At TSO, we are committed to:

- a high standard of excellence in every aspect of our business and in every corner of the world;
- ethical and responsible conduct in all of our business dealings and operations;
- respect for the rights of all individuals; and
- respect for the environment.

We expect the same commitments to be shared by all manufacturers of merchandise supplied to TSO (öManufacturersö). *At a minimum*, we require that all Manufacturers meet the following standards:

#### **General**

Manufacturers must comply with all applicable laws and regulations, including, but not limited to, those related to employment/labor, worker health and safety, and the environment.

All references to öapplicable laws and regulationsö in this Code of Conduct include local and national codes, rules, and regulations as well

as applicable treaties and voluntary industry standards.

**Child Labor**

Manufacturers will not use child labor.

The term "child" refers to a person younger than 15 (or 14 where local law allows) or, if higher, the local legal minimum age for employment or the age for completing compulsory education.

Manufacturers employing young persons who do not fall within the definition of "children" will comply with any laws and regulations applicable to such persons.

**Involuntary Labor**

Manufacturers will not use any forced or involuntary labor, whether prison, bonded, indentured, or otherwise.

**Coercion and Harassment**

Manufacturers will treat each worker with dignity and respect and will not use or tolerate corporal punishment, threats of violence, or other forms of physical, sexual, psychological, or verbal harassment or abuse.

**Nondiscrimination**

Manufacturers will not discriminate in hiring or employment practices, including salary, benefits, advancement, discipline, termination, or retirement on the basis of race, color, national origin/heritage, religion, age, nationality, social or ethnic origin, maternity, sexual orientation, gender, political opinion, or disability. Manufacturers will not retaliate against workers who complain in good faith about what they believe to be discrimination.

**Association**

Manufacturers will respect the rights of workers to associate, organize, and bargain collectively in a lawful and peaceful manner, without penalty or interference.

**Health and Safety**

Manufacturers will provide workers with a safe and healthy workplace in compliance with all applicable laws and regulations.

Manufacturers will also ensure that the same standards of health and safety are applied in any housing they provide for workers.

**Compensation**

Wages are essential to meeting workers' basic needs. Manufacturers will, at a minimum, comply with all applicable wage and hour laws and regulations, including those relating to minimum wages, overtime, maximum hours, piece rates, and other elements of compensation, and provide legally mandated benefits. Manufacturers must pay at least minimum wages required by law or wages consistent with local industry standards, whichever is greater. If local laws do not provide for overtime pay, Manufacturers will pay at least regular wages for overtime work. Except in extraordinary business circumstances, Manufacturers will not require workers to work more than the lesser of (a) 48 hours per week and 12 hours per week overtime, or (b) the limits on regular and overtime allowed by local law; where local law does not limit the hours of work, the regular work week in the country plus 12

hours overtime. In addition, except in extraordinary business circumstances, workers will be entitled to at least one day off in every seven-day period. Manufacturers must pay all vacation, holiday, and paid time off as required by applicable laws and regulations.

**Protection of the Environment** Manufacturers will comply with all applicable environmental laws and regulations.

**Other Laws** Manufacturers will comply with all other applicable laws and regulations, including those pertaining to the sourcing of components or raw materials, manufacture, pricing, sale, and distribution of merchandise.

**Subcontracting** Manufacturers will not use subcontractors for the manufacture of merchandise supplied to TSO or components thereof without TSO's express written consent. TSO may require, as one of the conditions of approval, that the subcontractor enter into a written commitment with TSO and comply with this Code of Conduct.

**Monitoring and Compliance** Manufacturers will authorize TSO and its designated agents (including third parties) to engage in monitoring activities to verify compliance with this Code of Conduct, including unannounced on-site inspections of manufacturing facilities and employer provided housing; reviews of books and records relating to employment/labor matters; and private interviews with workers. Manufacturers will maintain on site all documentation that may be needed to verify compliance with this Code of Conduct.

**Publication** Manufacturers will take appropriate steps to ensure that the provisions of this Code of Conduct are communicated to workers, including the prominent posting of a copy of this Code of Conduct, in the local language and in a place readily accessible to workers, at all times.

*The TSO Code of Conduct for Manufacturers is not a contract and does not create any contractual rights for TSO employees, Manufacturers, or third parties.*

## **VIII. APPENDIX**

### **DEFINITIONS**

#### **ADVANCE SHIP NOTICE ó ASN**

Pre-receipt information consisting of Purchase Order numbers and case contents by SKU.

#### **BILL OF LADING – BOL**

The legal document tendered to the carrier by the vendor/shipper at the time of pick-up.

#### **CASE**

A word used to refer to boxes of in-bound merchandise.

#### **ELECTRONIC DATA INTERCHANGE ó EDI**

A means of sharing information electronically between business entities.

#### **VENDOR NET-**

A Web based program in which the vendor can transmit ASNs to the DC, print UCC-128 Labels, and print TravelSmith Purchase Orders. Basic requirements include web access, Microsoft Word 2000, and a printer.

**ITEM**

A word used interchangeably with physical product, referring to an individual unit.

**LEAD CASE**

Case #01 of xx0. There is a lead case for every P.O. and Packing Slip. Lead case contains a packing slip inside the case and attached to the outside of the case.

**PACKING SLIP**

Interchangeable with Packing List. Document containing case level information by P.O. by shipment.

**PRO NUMBER**

A carrier's tracking number for a shipment to a particular ship destination.

**RN# (Registered Identification Number)**

It is a number issued by the Federal Trade Commission to U.S. businesses that manufacture, import, distribute, or sell products covered by the Textile, Wool, and Fur Acts.

**SKU**

Stock keeping unit. Is used to identify merchandise at the item, color and size level.

Example: Men's white oxford cloth shirt in medium:

Style 12345 (men's oxford cloth shirt)

Color WHT (white)

Size 1534 (neck/sleeve length)

**STYLE**

Used to identify a category of merchandise with the same item, color and size characteristics.

Example: Style 1234 all colors all sizes.

**UNIFORM CODE COUNCIL – UCC**

Establishes and promotes multi-industry standards for product identification and related electronic communication.

**UNIVERSAL PRODUCT CODE – UPC**

A twelve-digit ID Number used to uniquely identify companies and their products.